



***INTELLISPEC™***  
***FHCP 3X***  
***Addendum Series***  
***6***

SOFTWARE VERSION: 6.0 AND ABOVE

MANUAL PART NUMBER: 81698 REV. 01

## **Copyright Notice / Contact Us**

© 2021 Pressco Technology Inc. All rights reserved.

No part of this manual may be reproduced or transmitted in any form or by any means, electronic or mechanical, including photocopying and recording, for any purpose, without the express written permission of Pressco Technology Inc.

The contents of this manual are furnished for informational use only, are subject to change without notice, and should not be construed as a commitment by Pressco Technology Inc.

Written and designed at:

Pressco Technology Inc. World Headquarters

29200 Aurora Road

Cleveland, OH USA 44139-1847

TEL +1-440-498-2600

FAX +1-440-498-2615

[www.pressco.com](http://www.pressco.com)

Business Hours: Monday - Friday, 8:00am - 5:00pm Eastern Time

Customer Support:

Request technical support and remote support: [techsupport@pressco.com](mailto:techsupport@pressco.com)

24/ 7 Customer Support (for urgent system help): +1-440-498-2000

e-mail: Schedule a service visit: [dispatch@pressco.com](mailto:dispatch@pressco.com)

Request technical support and remote support: [techsupport@pressco.com](mailto:techsupport@pressco.com)

Customer Service Fax: +1-440-498-4761

## Table of Contents

Chapter 1 Pressco Introduction .....	7
About This Manual .....	7
Safety Considerations .....	8
Static Discharge Protection .....	8
Chapter 2 Safety Information .....	9
Health Warning - Photosensitive Epilepsy .....	9
Symbols Used With This System .....	10
Label Description - Intellispec .....	10
Warning Devices .....	11
Light Tree .....	11
Residual Risk .....	11
Intended Use .....	12
Prohibited Use .....	12
Personal Protective Equipment .....	12
Personnel Safety .....	13
Lifting Heavy Objects .....	14
Authorized Users .....	14
Spare Parts Usage .....	15
Chapter 3 System Specifications .....	16
Specifications - Intellispec Series 6 .....	16
Part and Part Handling Specifications FHCP S6 .....	16
Environmental Conditions .....	17
Sound Pressure Level .....	17
Electrical Specifications FHCP 3X S6 .....	17
Dimensions FHCP 3X Module S6 .....	18
Chapter 4 Installation .....	22
Shipping and Handling .....	22

Recommendations Prior to Installation .....	22
Utilities to be Supplied by Customer .....	23
Installation .....	23
Protective Earthing .....	23
Electrical Connection .....	24
External Connections FHCP S6 .....	25
Reject Valve Pneumatic Diagram .....	26
Air Supply Connection .....	26
Securing to Floor .....	26
Ventilation .....	27
Commissioning .....	27
<b>Chapter 5 FHCP 3X S6 System Overview .....</b>	<b>28</b>
User Interface Components .....	28
USB Ports .....	29
How to Select Menu Items .....	30
Mechanical Keyboard (MKB) .....	30
Biometric Login Device .....	31
<b>Chapter 6 FHCP 3X Inspection Module S6 .....</b>	<b>32</b>
Power On and Off FHCP S6 .....	33
Interlock for Computer Door .....	33
Accessing the Internal Components .....	33
Control Cabinet Components .....	35
Internal Components FHCP S6 .....	36
<b>Chapter 7 Part Changeover FHCP .....</b>	<b>39</b>
Part Changeover .....	39
Observe the Part Image .....	39
Camera Height Adjustment FHCP 3X .....	40
Guide Rail Adjustment FHCP 3X S6 (Optional) .....	42

Chapter 8 Wiring Diagrams FHCP 3X S6 .....	44
Wiring Diagram FHCP3X S6 Sheet 1 of 12 .....	44
Wiring Diagram FHCP3X S6 Sheet 2 of 12 .....	45
Wiring Diagram FHCP3X S6 Sheet 3 of 12 .....	46
Wiring Diagram FHCP3X S6 Sheet 4 of 12 .....	47
Wiring Diagram FHCP3X S6 Sheet 5 of 12 .....	48
Wiring Diagram FHCP3X S6 Sheet 6 of 12 .....	49
Wiring Diagram FHCP3X S6 Sheet 7 of 12 .....	50
Wiring Diagram FHCP3X S6 Sheet 8 of 12 .....	51
Wiring Diagram FHCP3X S6 Sheet 9 of 12 .....	52
Wiring Diagram FHCP3X S6 Sheet 10 of 12 .....	53
Wiring Diagram FHCP3X S6 Sheet 11 of 12 .....	54
Wiring Diagram FHCP3X S6 Sheet 12 of 12 .....	55
Chapter 9 Troubleshooting FHCP Systems .....	56
Lockout Instructions .....	56
Resetting the Part Tracker Board in FHCP .....	57
Restarting the FHCP System .....	57
Chapter 9 Extended I-O S6 .....	59
Extended I-O Board S6 .....	59
Extended I-O Signals S6 .....	60
Extended I-O Switch SW1 Selection .....	67
Extended I-O Circuits S6 .....	68
Extended I-O Configuration .....	69
Chapter 10 Maintenance .....	73
Cleaning the FHCP System Cabinet .....	73
Cleaning the Vision Processor Filter .....	73
Cleaning Optical Surfaces .....	74
Cleaning Glass Surfaces .....	74

Cleaning Plastic Surfaces - FHCP .....	75
Cleaning the Part Detector FHCP S6 .....	76

# Chapter 1 Pressco Introduction

---

Welcome!

Congratulations on your purchase of an Intellispec system! The Intellispec is a high-speed machine vision system designed specifically for product and online process monitoring. It is a powerful tool that provides inspection much more reliably than the human eye or sampling methods. The latest PC technology, powerful inspection algorithms, online adjustment capability, and inspection data storage allow the Intellispec to automatically inspect parts with extreme accuracy on high-speed lines.

The Intellispec will help you provide the highest quality of products shipped to your customers.

## About This Manual



**IMPORTANT:** *Keep this manual for future reference*

This book is considered an integral part of the system and should be kept handy for future reference as long as the system is being used in your plant.

The purpose of this manual is to describe the Intellispec Vision Processor and associated hardware. It is intended for trained users.

This manual:

- Is your responsibility to keep in good condition, in a dry place, and ready for consultation by the authorized users of the system.
- Contains the technology implemented at the time of selling and supplying the system and shall not be considered inadequate in case of technological enhancements in the machine or in the manual's illustrations.

Related books include:

- Intellispec Operator's Guide which has Operator-level user instructions, and is a good place to start if you are new to Intellispec
- Intellispec Software Guide which has Administrator-level user instructions

### **The following types of alerts may appear in this guide:**



**DANGER!** - Danger messages alert you to specific conditions that can cause serious or fatal personal injury. Danger messages give you important information which must be observed to prevent injury.



**WARNING:** - Warning messages indicate information which must be observed to prevent injury, data loss, or equipment damage.



**CAUTION** - Caution messages indicate important information which must be observed to prevent: loss of data, poor system performance, or equipment damage.

**Note:** Notes contain special information that warrants being set off from the body text as shown here.



**IMPORTANT** - Indicates prerequisites or information that must be observed to complete or understand a concept or task.

**TIP:** Provides helpful hints for completing a task.

---

## Safety Considerations

Observe the following safety warnings when operating the system or working near it:



*WARNING - Potential for projectiles to strike persons and cause injury. Keep clear of reject devices.*



*WARNING - Sensitive electronics and High Voltages may be exposed. Keep Processor Cabinet/ Electrical Control Box door closed.*

---

## Static Discharge Protection



*Caution - Electronic components can be damaged by static electricity discharge.*

Always observe the following precautions before removing, installing or handling any electronic components within the Inspection System:

- Wear an anti-static wristband which is grounded to the Inspection System.
- Stand on an anti-static, grounded floor mat, and lay circuit boards on the mat during any board replacement.
- Keep circuit boards in static shield bags when storing and transporting. Ensure the bag is sealed.

## Chapter 2 Safety Information

This section contains operator safety information that must be read before operating or servicing the system.



**WARNING** - This product contains no operator serviceable parts. Refer servicing to qualified personnel. To prevent electrical shock do not open cabinet doors whilst power is connected.



**WARNING** - Do not, under any circumstances, tamper with sealed machine parts or devices. This could result in the removal of protections that might create potentially hazardous conditions.



**CAUTION** - Possible hazardous optical radiation from LEDs. Do not stare at lamps.

### Health Warning - Photosensitive Epilepsy



**WARNING: PHOTOSENSITIVE EPILEPSY/ SEIZURES**

A small percentage of individuals may experience epileptic symptoms or seizures when exposed to certain patterns or flashing lights. Exposure to the flashing lights in vision inspection systems may also trigger epileptic symptoms or seizures in these individuals. These flashing lights may trigger epileptic symptoms or seizures in persons who have no history of epileptic symptoms or seizures. If you, or anyone in your family has an epileptic condition or has had seizures of any kind, consult your physician before operating this machinery.

IMMEDIATELY DISCONTINUE use and consult your physician if you experience any of the following symptoms while operating this machinery:

- Dizziness
- Altered vision
- Eye or muscle twitches
- Loss of awareness
- Disorientation
- Seizures
- Any involuntary movement or convulsion

***Epileptic symptom or seizure triggers vary from person to person. Some common triggers are:***









- Flashing lights used for vision inspection systems or fire alarms
- Certain video games or TV broadcasts containing rapid flashes or alternating patterns of different colors
- Bright, contrasting patterns such as white bars against a black background
- Flashing white light followed by darkness
- Stimulating images that take up your complete field of vision, such as being very close to a TV screen or computer monitor
- Certain colors, such as red and blue

**If you encounter something that might trigger epileptic symptoms or seizures without warning:**

- Do not close your eyes (this could cause a flicker effect)
- Do not look directly at the flashing lights or trigger source
- Do cover one eye with the palm of your hand immediately
- Do turn away from the flashing lights or trigger source

**Symbols Used With This System**

The following symbols are used on or near the Pressco system. Be aware of potential risk hazards.

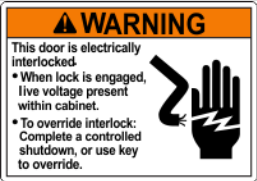
Symbol	Meaning
	CAUTION: Risk of danger. Refer to accompanying user documentation before use.
	WARNING: Risk of electric shock
	WARNING: Risk of burns from hot surface
	WARNING: Hand crush hazard
	On (supply)
	Off (supply)
	Alternating current
	Protective conductor terminal
	Arc flash and shock hazard
	Electrical interlock

**Label Description - Intellispec**

The following illustration shows an example label that you will find on the Intellispec system components.

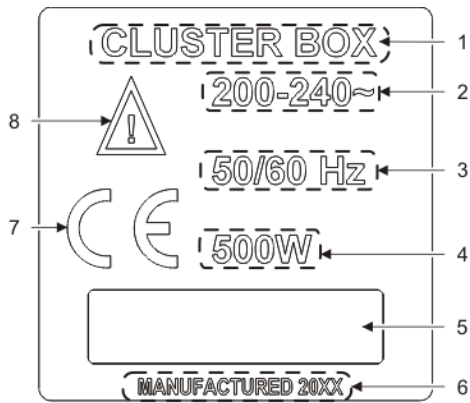

- 1) Name of component. NOTE: The Chromapulse model is listed on the front panel of the module.
- 2) Voltage range in Volts AC
- 3) Frequency range in Hertz (Hz)
- 4) Maximum rated power in watts (W) with all accessories or plug-in modules connected
- 5) Serial number is listed in this box
- 6) Year of manufacture
- 7) Component certification
- 8) Risk of danger. Refer to accompanying documentation before use.

---

## Warning Devices

The Pressco system has warning devices that indicate system failure or report excessive defects or warnings for your production line. These include an optional light tree, alarms and indicators on screen, and audible warnings (depending on system).

---

## Light Tree

The optional light tree is mounted on a pole in a customer-specified location.



The light tree color segments represent each alarm or system condition. A color segment may appear for more than one alarm condition.

---

## Residual Risk

The Pressco system has been designed to minimize any danger of personal injury. However, the system uses rejection devices to remove defective product from the production stream. Also, the electronics cabinets contain risk of shock if they are opened.

Observe the following safety warnings when operating the system or working near it:



**WARNING** - Potential for projectiles to strike persons and cause injury. Keep clear of reject devices.



**WARNING** - Sensitive electronics and High Voltages may be exposed. Keep Processor Cabinet/ Electrical Control Box door closed.

## Intended Use

**Type of Process** The Pressco system is intended to monitor container and other special manufacturing processes and identify non-conforming product.

**Intended Use** The Pressco system is designed and constructed for use in an indoor industrial environment, always sheltered from the weather.

**Space Required** The Pressco system and accompanying sensors must be installed in a place that will enable safe and easy installation, size changeover, user operation, and maintenance procedures.

## Prohibited Use



**WARNING** - If this instrument is not used as specified, the protection provided by the equipment could be impaired. This instrument must only be used in a normal condition (in which all means of protection are intact).



**Important** - The Pressco system should NOT be used for any purpose other than specifically indicated in the section titled "**Intended Use**" above.

The following uses are not intended:



Use in an explosive environment



Use in a flammable environment



Use in a damp, moist, or wet environment, except where specifically indicated

## Personal Protective Equipment



**Important** - Always follow the safety requirements of your plant in addition to the recommendations below.

We recommend, at minimum, use of the following Personal Protective Equipment (PPE):



Protective clothing



Protective gloves



Protective ear plugs or headphones



Protective eye wear



Protective foot wear

## Personnel Safety

The following rules are recommended to ensure the safety of personnel in charge of machine operation and maintenance.

### *During machine operation:*



Only one operator is needed to operate the machine. All others must keep at a safe distance.



Operators must be familiar with all machinery connected to the Pressco equipment and know how to use emergency stop devices.

Note: the emergency stop devices may not be connected directly to the Pressco equipment, but it is important to know how to use them.



Before putting the Pressco system online, the operator must ensure that all safety devices used with all connected machinery are in place and operational.

Do not operate with guards removed.



The operator must maintain maximum focus on his work and be alert throughout his shift. If this is not the case, immediately inform the shift supervisor.

### *When carrying out maintenance or repair work:*



Disconnect master switch. For switch locations, refer to the Power Up and Power Down section.



Before starting the machine, ensure that no person is close to the machine.



If maintenance or repair requires the disconnection or removal of safety or protection systems, this operation must be supervised by authorized personnel who must ensure the prevention of personal injury or damage to the machine. All machine movements must be performed with limited speed and limited movements.



Maintenance or repair work on electrical components must be carried out exclusively by authorized, trained personnel. When running tests with power connected, you must strictly comply with the rules provided.



Personnel working on higher parts of a machine must wear a harness and hook it on to the structure and must always move with extreme caution.



Never perform lubrication or maintenance procedures on mechanical parts with the machine running.

### *For your safety, do not:*







Open safety guards during machine operation



Perform maintenance and repair while the system is running

## Chapter 2

-  Lean on the machine
-  Sit on the machine components
-  Use the machine for purposes other than those listed in this manual
-  Modify parts of the machine
-  Allow unqualified personnel to operate or perform maintenance procedures on the machine

---

### Lifting Heavy Objects

 **CAUTION** - Some components are heavy. Take proper precautions to prevent personal injury or damage to equipment. If you are not capable of lifting the object alone, ask a capable person to help lift the object, or use a mechanical lifting device

The components do not have handles to lift the equipment. Be sure to:

- Lift equipment from the bottom - do not use wires, brackets, nor other protrusions
- Keep fingers away from sensor lenses to keep the equipment clean
- Proceed slowly

 **WARNING**- The Pressco cabinets must NOT be lifted by one person. Use a mechanical lifting device, and ask another person to assist you.

 Do not twist your body when moving the load. Instead take small steps with your feet turning until you are in the correct position.

#### **To safely lift equipment:**

1. Stand close to the load and center yourself over it with your feet shoulder width apart.
2. Tighten your abdominal muscles.
3. Keeping your back straight, bend your knees and squat down to the floor.
4. Get a good grasp on the load with both hands.
5. Keeping the load close to your body, use your leg muscles to stand up lifting the load off the floor. Your back should remain straight throughout lifting, using only the muscles in the legs to lift the load.
6. To place the load in the appropriate spot, bend at the knees using only your leg muscles to lower the load.

---

### Authorized Users

Trained machine operators, mechanic and electrical maintenance staff, and plant managers are considered authorized users of the Pressco system. These users should carefully read the information contained in this manual. The plant manager must ensure that the safety recommendations included in this manual are observed.

 **WARNING** - *Allowing workers who are unfamiliar with the production process to operate the Pressco system could result in hazard risk.*

If you are unclear about any part of this manual, contact Pressco Technical Support.

 **Important** - *No worker should ever operate the system outside of his/ her own area of competence and responsibility.*

**Proper Operation:** Only one worker is to operate the system at any given time. The correct position for the operator is in front of the user interface monitor or control enclosure (if applicable).

**Repairs:** Any repair on the system shall be carried out exclusively by Pressco Technology Inc. service personnel or by other service expressly authorized by Pressco Technology Inc.

---

## Spare Parts Usage

The following restrictions apply to replacing parts:

 **WARNING** - *Using spare parts that are not designed to Pressco's specifications can compromise the safety and effectiveness of the Pressco system.*

- The use of parts that are not within Pressco's design specifications is prohibited. This prohibition applies in particular when the parts involved contain or are connected with safety devices.
- Before resuming production, make sure all safety devices are in working order.

Pressco Technology Inc. shall not be liable in any way if any of the above-described directions are not complied with.

To obtain a spare parts list, contact the customer service department at Pressco.

Pressco's technicians are available to help customers, in their own plant, to solve any problem that might arise during use and maintenance of the system.

## Chapter 3 System Specifications

---

This instrument has been designed and tested in accordance with Publication EN61010-1 (2010) Safety Requirements for Electrical Equipment for Measurement, Control and Laboratory Use and has been supplied in a safe condition. The instruction documentation contains information and warnings which must be followed by the user to ensure safe operation and to maintain the instrument in a safe condition.

---

### Specifications - Intellispec Series 6

The following sections contain electrical specifications and measurements for components of the Intellispec Series 6 system. Your system contains only the components necessary for your application.

---

### Part and Part Handling Specifications FHCP S6

#### Closure/ Finish Size

The range of cap/ finish sizes that the FHCP system will handle are: 25mm to 38mm outer diameter. Sports caps and other specialty caps must be evaluated by Pressco Technology Inc. prior to inspection.

#### Part inspection requirements

- Liquid droplets must be removed from the inspection area (cap and neck ring)
- The fill level inspection is based on inspecting a stable fill level that is unobstructed by the support ring or other bottle features.

#### Burst Rate

The maximum conveyor rate is 5500 parts per minute, maximum. Parts will not be inspected properly above this rate.

#### Conveyance

- Bottles must be presented such that there is no slippage between the bottle and conveyor while the bottle is between the vision inspection module part detect and rejecter.
- Conveyors must have a ramp function so that upon starting and stopping, bottles do not slide on the conveyor surface.
- Conveyors must have a suitable chain tension such that under normal operation, starting or stopping the conveyance surface does not stretch or compress between the vision modules and the drive wheels.

#### Positioning

In order to accurately measure cap application geometry, bottle must be consistently presented to the vision inspection module. Depending on the range of bottle diameters to be inspected, adjustable rails may be necessary to ensure that bottle centerlines remain consistent on the conveyor.

- Bottles should be positioned +/- 0.125 inches laterally
- Bottles should be upright and perpendicular to the conveyor +/- two degrees

Deviation from these guidelines could potentially cause bottles to be falsely rejected.

## Spacing

In order to properly inspect and accurately reject bottles: Bottle Spacing on Conveyor is > 50 mm side-wall to sidewall gap. If this spacing is not achievable, narrower spacing will be evaluated on a case by case basis by Pressco Technology Inc.

---

## Environmental Conditions

The Intellispec system is designed to be safe in the following environmental conditions:

*Note: Please consult Pressco Technology Inc. if your environmental conditions are outside of those listed.*

Condition	Specifications
Indoor/ outdoor use	Indoor use only
Altitude	Up to 2000 meters
Operating Temperature	5 °C to 50 °C
Storage Temperature	0 °C to 70 °C
Humidity	Maximum relative humidity 80 % for temperatures up to 31 °C decreasing linearly to 50 % relative humidity at 50 °C
Mains supply	Voltage fluctuations up to ± 10 % of the nominal voltage
Overvoltage protection rating	Transient overvoltage typically present on MAINS supply NOTE: the normal level of transient overvoltages is impulse withstand (over-voltage) category II of IEC 60364-4-443.
Rated pollution degree	This instrument is designed for use in Installation Category II and Pollution Degree 1 as per EN61010-1 and EN60664 respectively.



*Warning - This is a Class A product. In a domestic environment this product may cause radio interference in which case the user may be required to take adequate measures.*

---

## Sound Pressure Level

The horn on the optional light tree has a maximum 105dB level at 1 meter distance in front of the horn. Use proper hearing protection as specified by your plant safety instructions.

---

## Electrical Specifications FHCP 3X S6

120 V FHCP 3X (model 81311):

## Chapter 3

- Volts – 120VAC
- Frequency – 50/60Hz
- Power – Inspection System – 600W max.
- Air Conditioner – 690W max.

230 V FHCP 3X (model 81312):

- Volts – 230VAC
- Frequency – 50/60Hz
- Power – Inspection System – 900W max.
- Air Conditioner – 663W max.

---

### **Dimensions FHCP 3X Module S6**

#### **Module placement with respect to the conveyor and bottle**

The measurements are in inches. The numbers in brackets are in millimeters.

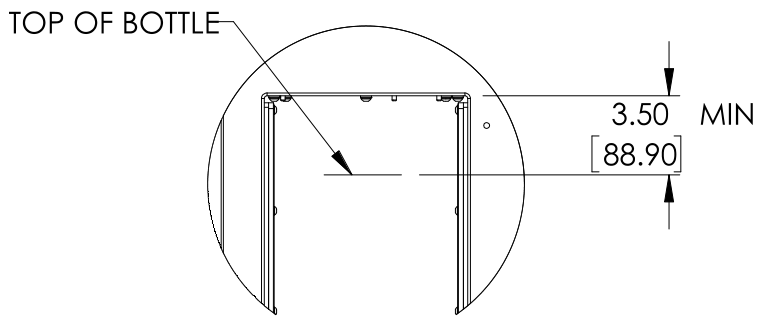

DETAIL A  
SCALE 1 : 8

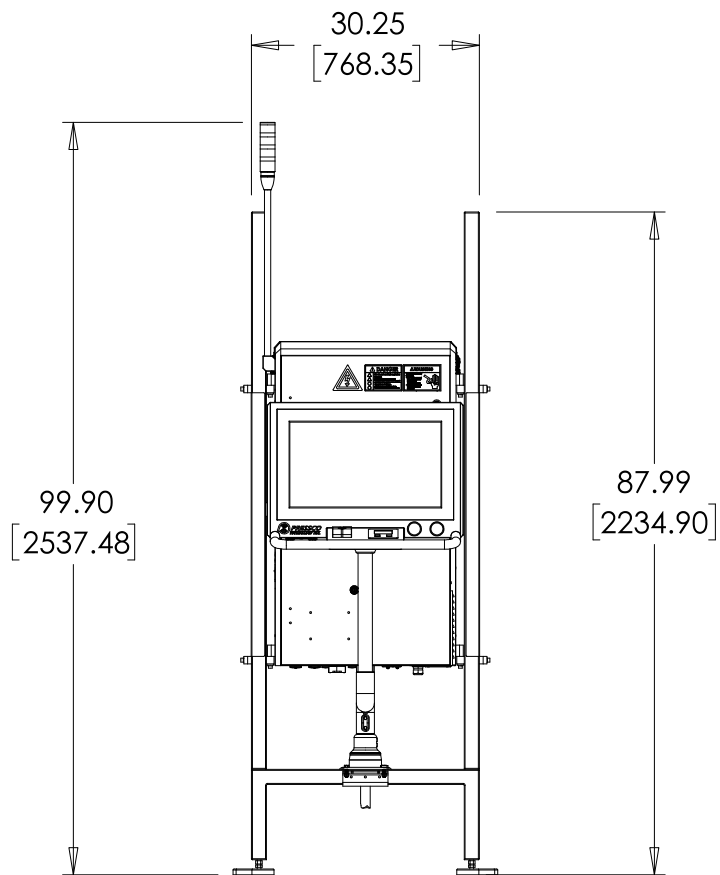

See also the illustrations below.

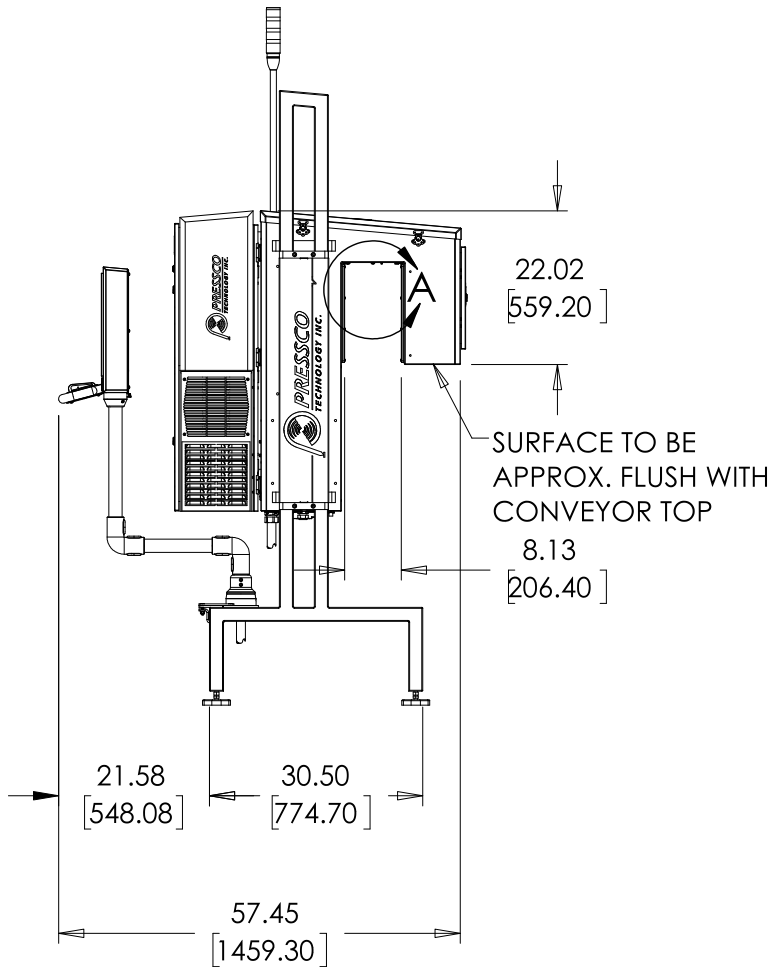

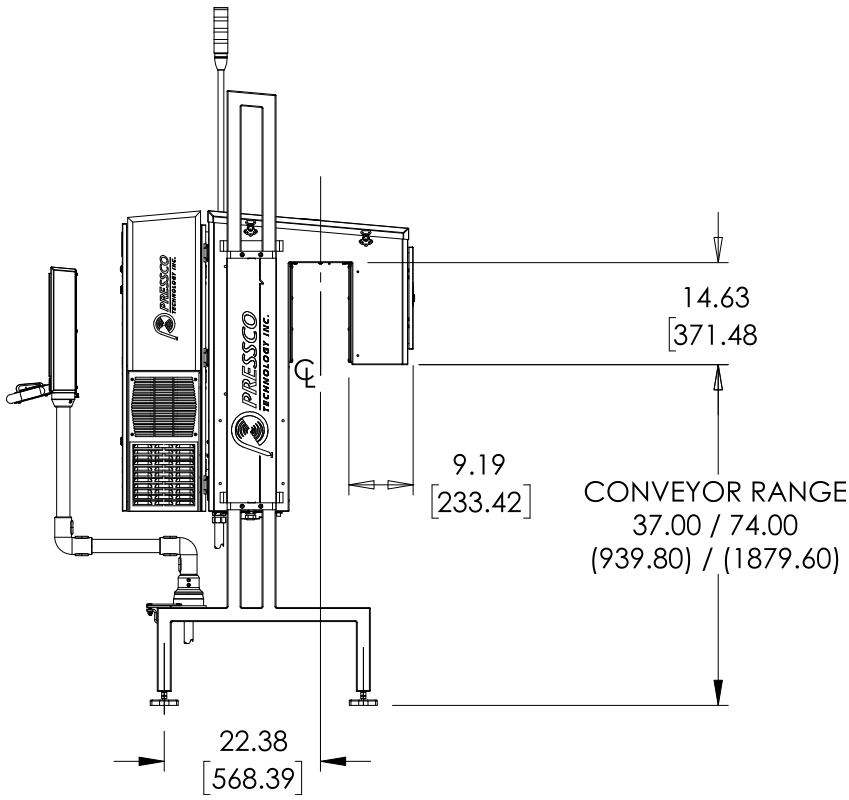

# Chapter 4 Installation

This section contains information about installation requirements and preparations that need to be complete before installing the system.

## Shipping and Handling

Pressco Technology Inc. ships unassembled components in packing cases designed to protect the contents during handling and from exposure to weather.

Unless otherwise specified in the contract with the machine order, the Customer shall supply Pressco Technology Inc. with the means and equipment necessary for the unloading, lifting, and handling of machine parts. Pressco Technology Inc. deems it important to have one of their technicians supervise the process of unloading, handling, and lifting the machine. The technician can give useful advice as to the logical sequence in which the components should be unpacked and positioned for ease of assembly.

 **WARNING** - Only qualified personnel must be involved in the operation of unloading, handling, and lifting the machine. Pressco Technology Inc. shall not be liable for damage to components and/or personal injury resulting from the involvement of unauthorized personnel and/or failure to comply with the directions provided in this manual in relation to lifting and transport.

 **Important** - The site supervisor will be responsible for ensuring that all the various mounting phases are carried out safely and in compliance with current regulations.

After the machine is delivered, check for any damage that might have occurred during shipping. In case of damage, contact Pressco Technology Inc.

In handling the machine, always keep it close to the ground.



We recommend using a forklift truck with adequate capacity and forks to suit the weight to be lifted (machine plus packaging).

The dimensions and weight of a crate are listed below. Note that this is the maximum size and weight. The size and weight of the crate may be less depending on your configuration. You may receive multiple crates depending on your configuration.

Size (full Intellispec system)	152.4 cm x 124.46 cm x 152.4 cm (60 x 49 x 60 inches)
Weight (full Intellispec system)	453.592 kg (1000 lbs.)

## Recommendations Prior to Installation

Before the machine is installed, the Pressco installer, together with the Customer (or representative) shall check the following criteria in the environment where the machine is to be installed:

- Work required by contract for the installation of the machine has been carried out
- The plant layout drawing that describes where the machine will be installed is the final drawing agreed to by Pressco Technology Inc.
- The space and height required for installation are actually available

- Only the components included in the installation layout are present in the area where the machine is to be mounted. Ensure no machines or components have been added at a later stage that might hinder mounting or make it more difficult. Should this be the case, immediately contact Pressco's Project Engineering personnel to arrange a suitable solution to the problem.

We recommend the following prior to machine installation:

- Transport the machine in its packaging to the area where it will be installed to minimize possibility of damage
- Carefully remove the packaging material and check components for damage
- Check tightness of mechanical components, as they can loosen during transport
- Prepare the compressed air mains line. Before making final connections, ensure that the pipes are clean and free from any debris.

---

## Utilities to be Supplied by Customer

The following utilities are required to operate the Pressco Intellispec system. Before making connection, make sure the utility matches the technical specifications. More than one connection of the utilities may be required depending on the number of modules installed. Refer to specific wiring diagrams.

Utility	Requirements
Air supply for rejection device	Pipe size must be such that there will be no pressure decrease during machine operation. Air must be dry and free of oil.
Electrical supply	<p>Provide one each electrical socket to comply with:</p> <ul style="list-style-type: none"> <li>• User interface electrical specifications (use the specifications that apply to your system)</li> <li>• Integrated tunnel electrical specifications (if applicable)</li> <li>• Cluster box electrical specifications (if applicable)</li> </ul>
Internet connection (optional)	Provide a shielded ethernet cable to use Pressco's remote support through the Internet.

---

## Installation

Pressco Technology Inc. recommends that the machine be installed and assembled by Pressco's specialized technicians. This is of vital importance for correct machine operation.



**WARNING** - Pressco Technology Inc. shall not be liable in case of failures or damage to property and/or personal injury resulting from or connected with assembly if this has been carried out by unauthorized personnel, or is not in compliance with the indications given in this manual.

To carry out production and cleaning/ servicing operations, it is important for the machine to have a minimum amount of space all around and away from walls.

---

## Protective Earthing

This product must be grounded (earthed). If it should malfunction or break down, grounding provides a path of least resistance for electric current to reduce the risk of electric shock.

 **DANGER** - Improper connection of the equipment grounding conductor can result in a risk of electric shock. Check with a qualified electrician or service technician if you are in doubt as to whether the product is properly grounded.

### **Cord Connected Equipment**

The product will be equipped with a supply cord having an equipment grounding conductor and a grounding plug. The plug must be plugged into an appropriate outlet that is properly installed and grounded in accordance with local codes and ordinances.

Do not modify the plug provided with the product - if it will not fit the outlet, have a proper outlet installed by a qualified electrician.

### **Cable Direct**

This product must be connected to a grounded metal, permanent wiring system, or an equipment grounding conductor must be run with the circuit conductors and be connected to the equipment grounding terminal.

---

## **Electrical Connection**

Make sure that the power outlet voltage matches the voltage required by the machine. Refer to the electrical specifications and wiring diagrams for your system.

 **WARNING** - Power Switch is the power disconnect device. Do not position the equipment such that access to the disconnect switch is impaired. If not readily accessible (such as within a rack or mounting out of reach), an additional disconnect device should be installed that can isolate the Live and Neutral lines of the mains power supply, whilst leaving the protective earth intact.

---

## External Connections FHCP S6

These are the connections on the outside of the module, the view from underneath. For more information, look at the wiring diagrams.

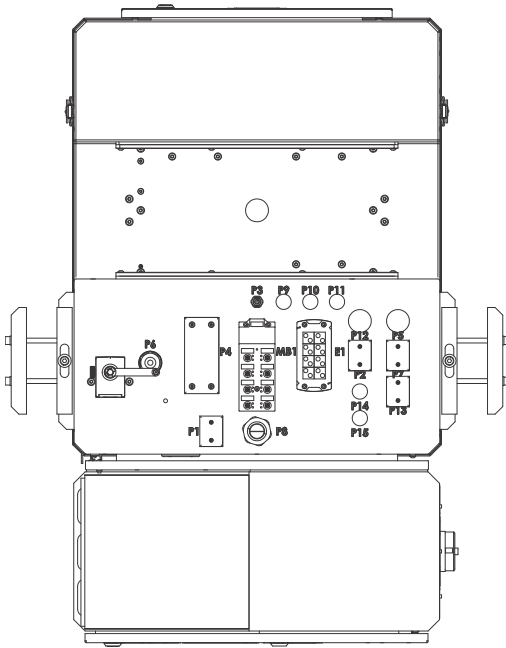

MB1 - 8 port I/O box

E1 - ethernet cable entry

P1 - 60VDC in (optional - not used when AC powered)

P2 - light tree (optional)

P3 - encoder in

P4 - embedded I/O (optional)

P5 - multizone tracking cable entry (optional)

P6 - AC power in (optional - not used when DC powered)

P7 - 60VDC out 1 to cluster box/ inspection module (optional)

P8 - user interface entry (optional)

P9 - encoder out (optional)

P10 - fallen bottle sensor 1 (optional)

P11 - fallen bottle sensor 2 (optional)

P12 - multizone reject cable entry (optional)

P13 - 60VDC out 2 to cluster box/ inspection module (optional)

P14 - trigger/ power out 1 from slave module (optional)

P15 - trigger/ power out 2 from slave module (optional)

## Reject Valve Pneumatic Diagram

This diagram shows the reject device connection to the 8-port I/O box. This is for Intellispec systems.

8-PORT I/O BOX  
57006

REJECT VALVE PNEUMATIC DIAGRAM

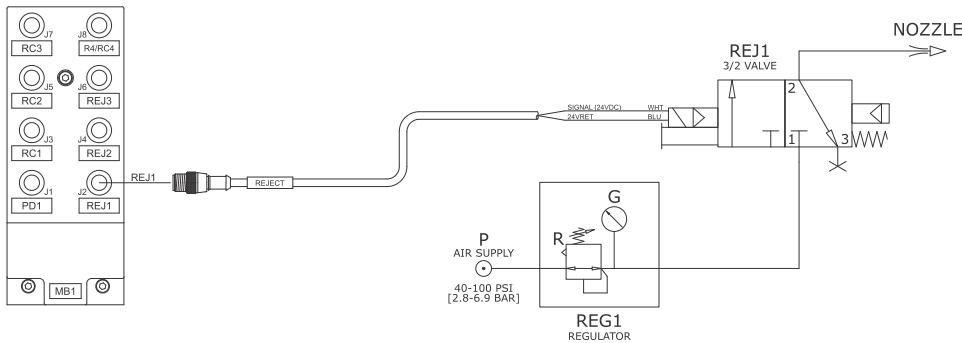

## Air Supply Connection

Connect plant air supply to the Filter Regulator Lubricator (FRL). Pneumatic requirements: 60 psi, 16 CFM, 3/8 NPT Inlet, and is for the purpose of rejecting parts.

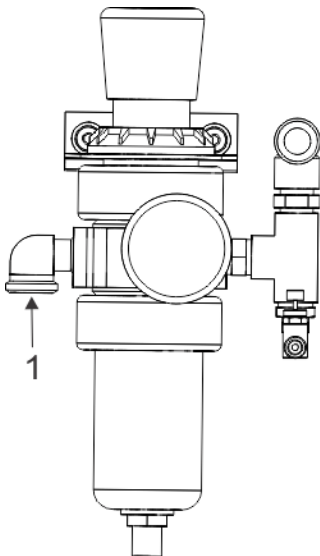

1 - Air supply connection

## Securing to Floor

The ground under the machine must be sufficiently solid to sustain the machine mass at the support points. In addition, the floor must be free of bumps, grooves and other surface irregularities. The surface must be flat enough so that the leveling feet of the machine bear weight across their entire surface.

Attach the machine to the floor by installing M12 x 50mm lag bolts into the floor through the hole on the frame foot pad. Do this on one hole in each foot.

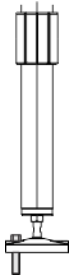

## Ventilation

Place the Pressco Intellispec components in a position with adequate ventilation to allow proper air flow through the air filters.

Component	Spacing
User Interface	Leave 1 meter [39 inches] clear around machine
Cluster box (not used on all systems)	Leave 100 mm clear in front of the fan and vent

## Commissioning

Before placing the machine into operation, make sure the following checks are completed:

Completed	Yes	No
Positioning and leveling of the unit		
Connection of compressed air line to connection points		
Connection of power supply to vision processor cabinet		
Connection of power supply to cluster box (if applicable)		
Connection of power supply to integrated inspection module(s) if applicable		
Proper wiring from user interface cabinet to sensor module(s) and cluster box (if applicable) using the wiring diagrams		

## Chapter 5 FHCP 3X S6 System Overview

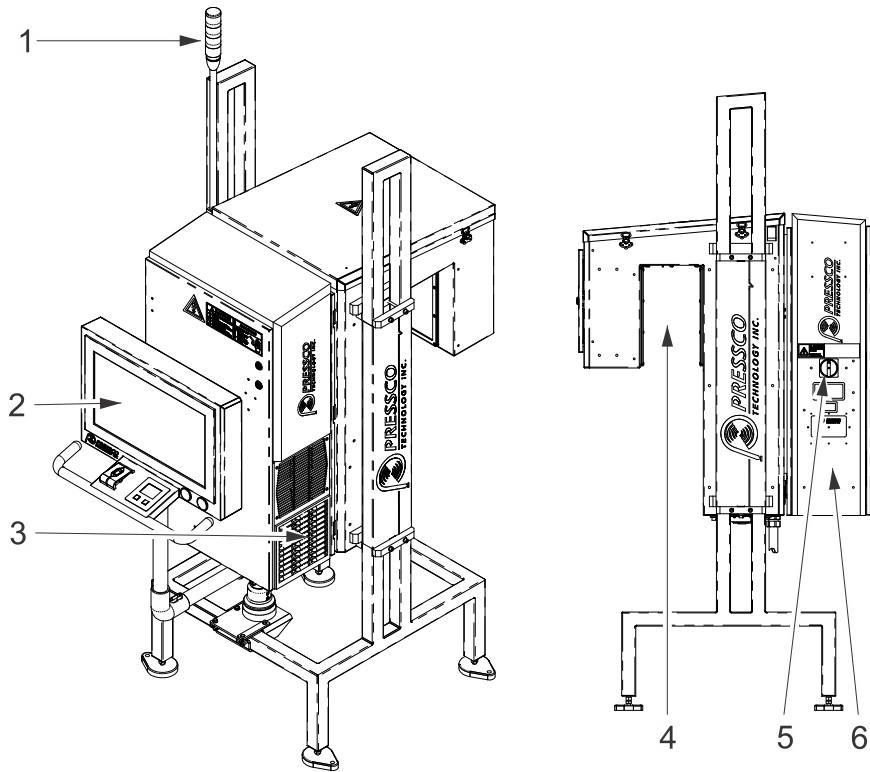

- 1) Light tree
- 2) User interface
- 3) Air conditioner
- 4) Tunnel through which parts flow. Plastic windows shield the cameras inside the module.
- 5) Power disconnect switch DISC1
- 6) Intellispec control cabinet

### User Interface Components

To operate the software of the FHCP system, use the monitor and associated components, shown below.

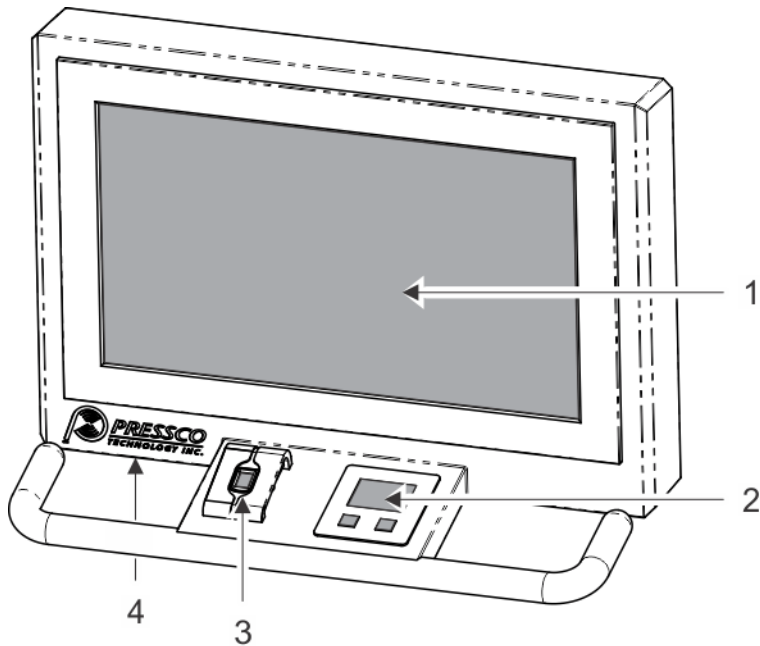

- 1) Touch Screen Monitor
- 2) Glide pad with buttons to move cursor and select items on the screen.
- 3) Biometric login device
- 4) Two USB convenience ports - underneath:
  - Outside (towards left side of monitor) used for jump drive to create Support Package
  - Inside (towards center of monitor) used for the Mechanical Keyboard (MKB)

---

## USB Ports

The USB ports are located underneath the left side of the user interface. A protective cover can be removed when you use the USB ports, and replaced when you are finished. See the drawing with the location of the USB port: ["User Interface Components" on the previous page](#)

Use the USB ports when you are:

- Importing or Exporting Part Programs from another system [How to Create, Copy, or Import a Part Program](#)
- Exporting user accounts
- Importing user accounts
- Creating a Support Package
- Saving images, especially to send with a support package ([How to Save Images](#))
- Using the Mechanical keyboard - use the inner port towards the center of the monitor

 The USB port is not for charging your phone! Only use these ports to import or export data.

## How to Select Menu Items

Use the glide pad to select, interact with, and change active objects on the screen. The glide pad will be required for all inspection editing tasks. The glide pad [item A] is located next to the Biometric login device, as shown below.

Under the glide pad are two buttons. Use the left button [item B] to select and activate objects on the screen. Use the right button [item C] to call up a context-sensitive menu related to the area or object clicked.

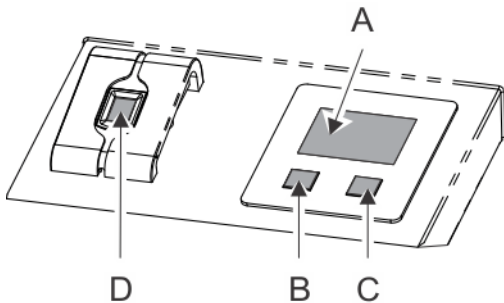

The following table shows the actions available for the glide pad and buttons, and the results of those actions.

Item	Action	Result
A -glide pad	Point (move pointer with the glide pad)	Display Tool Tip when hovered over active object
B	Click (Left-click)	When the pointer is over an active object, a click initiates various actions. Nothing happens when the pointer is clicked on a disabled object.
B, B	Double-click	When the pointer is over an active object, a double-click initiates various actions. For example, edit an inspection.
C	Right-click	Display a context-sensitive menu when you click on an enabled object. The context-sensitive menu often contains functions that are also available in a menu bar or other screens. For example, add a point to a polygon.
B + A	Drag (hold the left button while moving your finger on the glide pad)	Examples: move a selected Region of Interest (ROI) around an image or move an inspection in a Tree View to change the order of execution.
D (Biometric login device)	Log in or out of the software	User is logged in or out.

## Mechanical Keyboard (MKB)

The system supports the temporary connection of a conventional mechanical keyboard using one of the available USB ports. This keyboard will mostly be used for system level tasks such as BIOS configuration, Network configuration, and System level setup.



The keyboard:

- Is primarily used by Pressco Field Service Engineers
- Is stored inside the Vision PC chassis
- Requires a stable location when in use

---

## Biometric Login Device

The Biometric Identification login device is used to log in and out of the Pressco system. This device is optional and must be purchased with the system.



To log in with this device, press your finger to the device. The following are conditions for use:

- You must use the same finger as initially set up by your administrator
- If you do not know how your account was set up (or which finger you used), contact your administrator
- If, after three tries, the Pressco does not recognize your finger print, you must log in using the On Screen Keyboard (OSK)
- If, after three tries, the Pressco does not recognize your finger print, you must log in using the On Screen Keyboard (OSK)

## Chapter 6 FHCP 3X Inspection Module S6

This section is for models 81311 and 81312

This module is available in a 120V or 230V configuration.

This module performs several functions: it measures the fill level of the liquid in the container and it also inspects 270° of the closure to verify the closure is present, is installed properly, and it confirms proper cap color. It sends the inspection data and images to the Intellispec Vision System for processing.

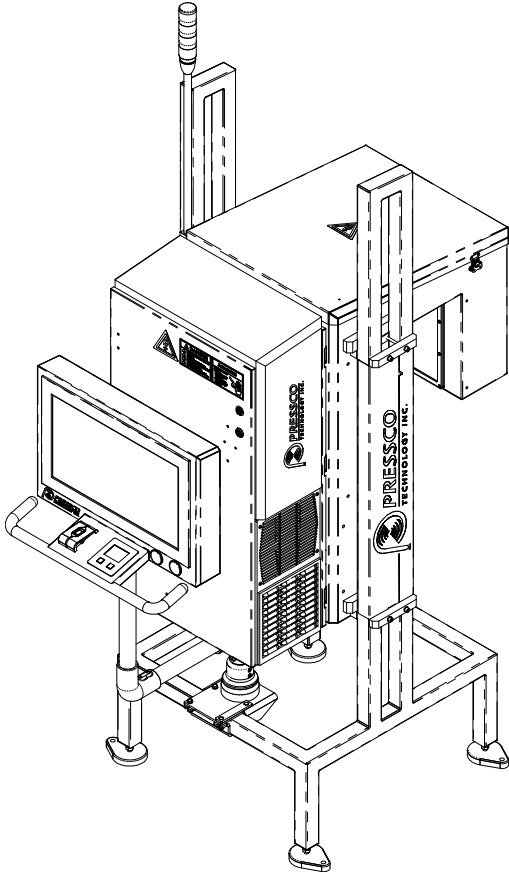

---

## Power On and Off FHCP S6

To turn the power on or off, turn the main power switch (S1).

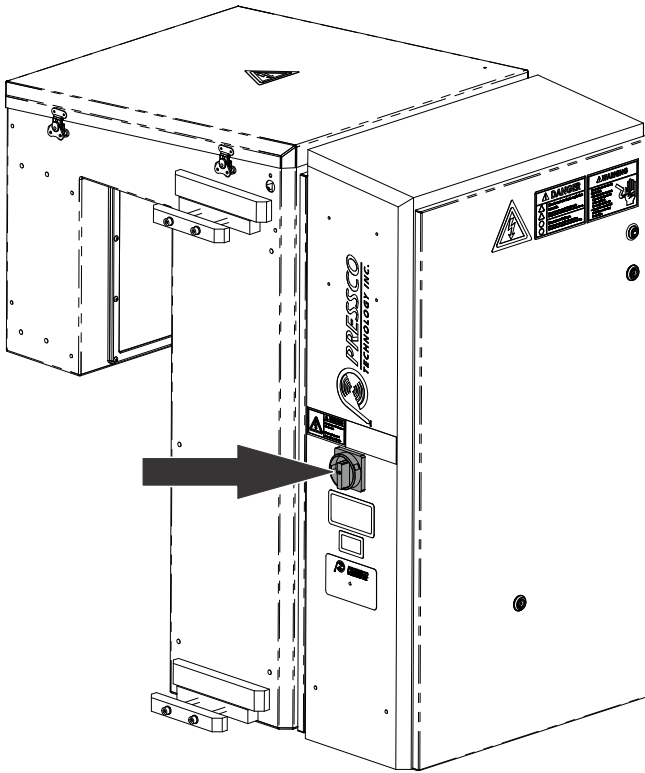

---

## Interlock for Computer Door

At the top of the computer door is an electrical interlock that prevents the door from opening. The only way to open the door is to use a key in the defector. This allows only **AUTHORIZED SERVICE PERSONNEL** to access the inside of the computer while the power to the unit is still applied. See *Accessing the internal components*.



*Warning - The door is electrically interlocked. When the lock is engaged, live voltage is present within the cabinet. To override the interlock, complete a controlled shutdown, or use the key to override.*

If the door is open, you can push it shut and the interlock switch will engage. It is spring-loaded.

---

## Accessing the Internal Components

To access the components inside of the FHCP computer, you will need two keys, which are supplied with the system.



*Warning - Even when the system is powered down, there is still voltage present at the UPS. Only **AUTHORIZED PERSONNEL** should attempt to open the system. We recommend that only **AUTHORIZED PERSONNEL** have access to the keys.*

## Chapter 6

1 - Standard key



2 - Interlock key



The standard key [item 1] opens most of the locks on the system, and the interlock key [item 2] opens the Interlock for computer door.

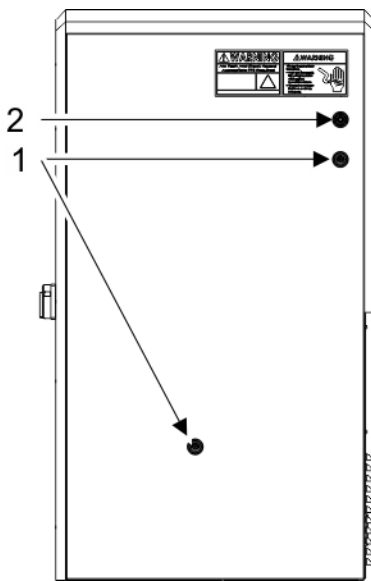

## Control Cabinet Components

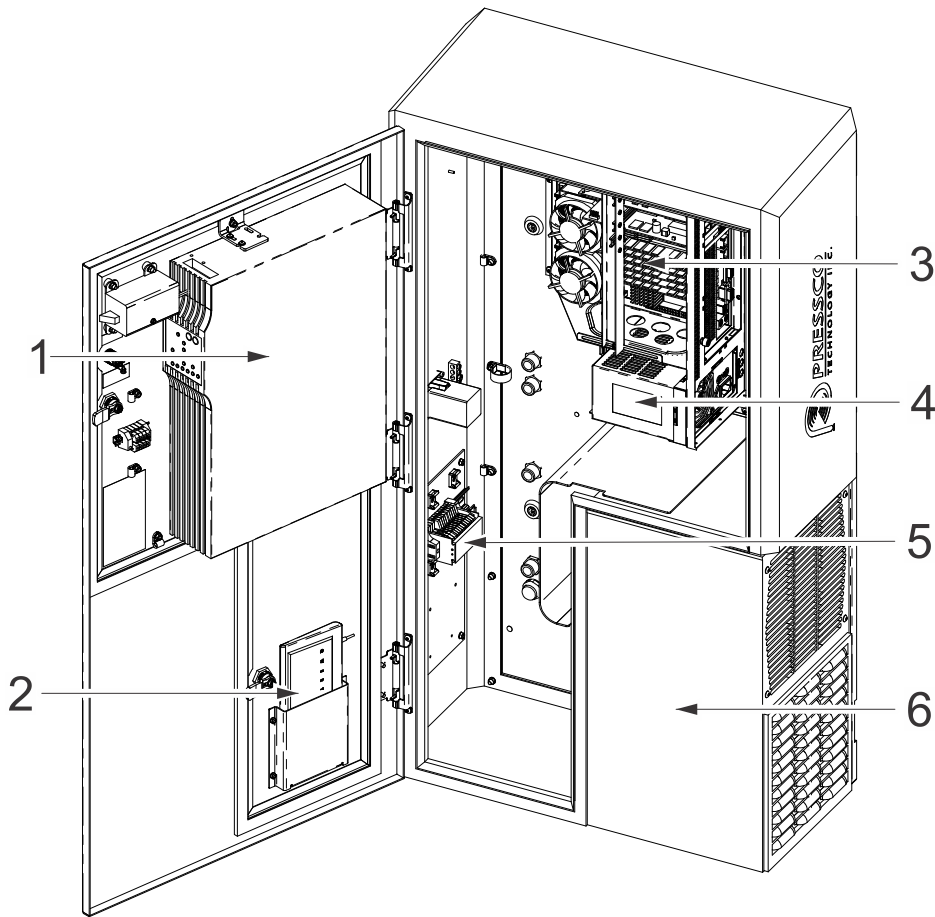

- 1) UPS - Uninterruptible Power Supply
- 2) Mechanical Keyboard (MKB)
- 3) Vision Processor Computer
- 4) Computer power supply
- 5) TB2 - Terminal block 2
- 6) Air conditioner

## Internal Components FHCP S6

These are the internal components of the inspection module.

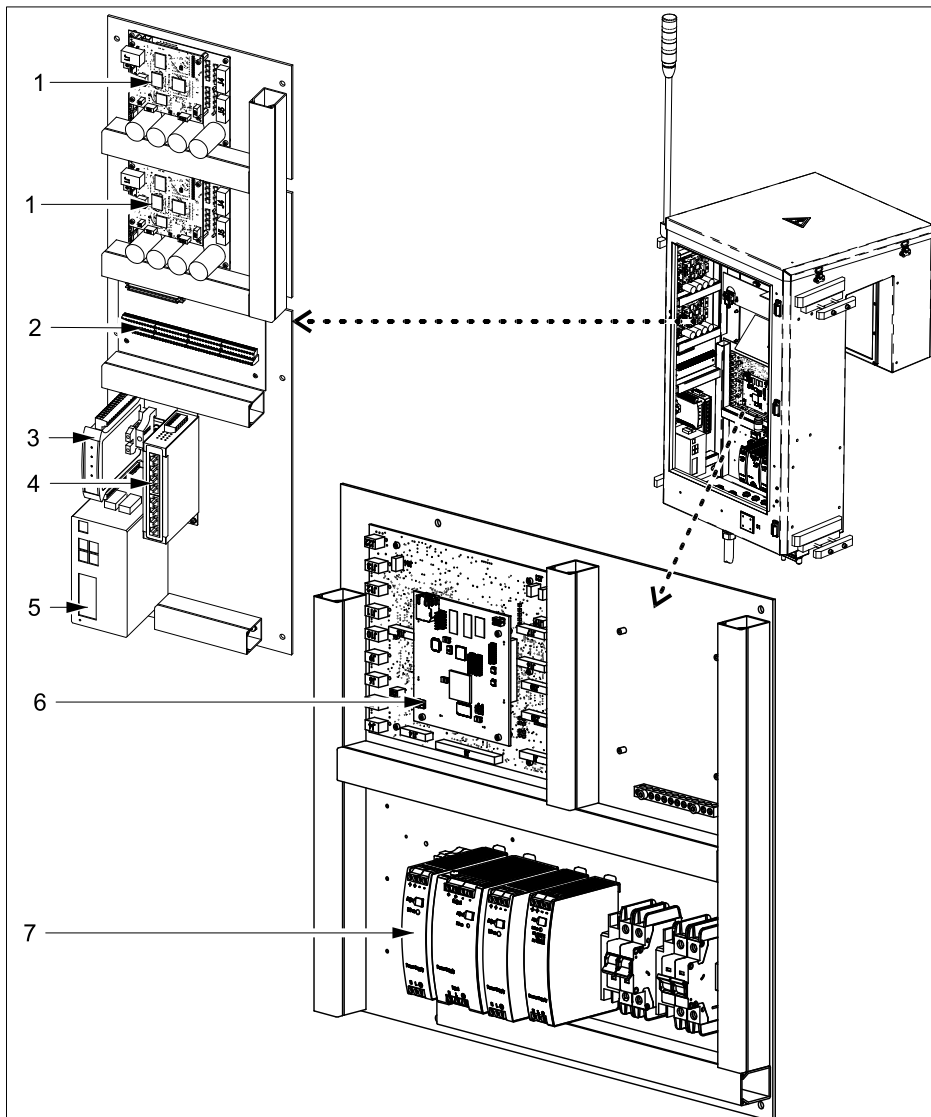

- 1) Driver/ light control (part number 66459)
- 2) Extended I/O board (part number 75626)
- 3) Encoder Splitter (Optional kit Encoder Splitter RX/TXD part number 80343)
- 4) Switch Ethernet Managed 8-Port 10/100/1000T (Part number 70551)
- 5) Ethernet switch 8 port (part number 81100)
- 6) 8 Channel Part Tracker (part number 78524)
- 7) TB1 - "TB1 Terminal Block Assembly 120V" on the next page or "TB1 Terminal Block Assembly 230V" on page 38

## TB1 Terminal Block Assembly 120V



**WARNING** - Disconnect the product from the mains supply before replacing the fuse(s).

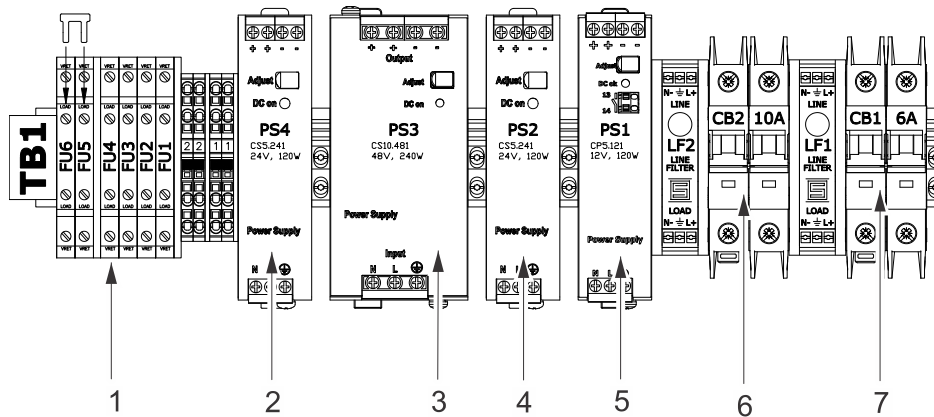

**FUSES:**

- FU1 - 5A, 250V
- FU2 - 5A, 250V
- FU3 - 5A, 250V
- FU4 - 5A, 250V
- FU5 - 5A, 250V
- FU6 - 5A, 250V

- 1) Fuse block. Note: a 2-pole jumper is installed in the load terminals of FU5 - FU6.
- 2) PS4 - POWER SUPPLY 24VDC 120WATT DIN MOUNT 100-240VAC
- 3) PS3 - POWER SUPPLY 48VDC 240WATT DIN MOUNT 100-240VAC
- 4) PS2 - POWER SUPPLY 24VDC 120WATT DIN MOUNT 100-240VAC
- 5) PS1 - POWER SUPPLY 12VDC 120WATT DIN MNT 100-240VAC
- 6) CB2 - CIRCUIT BREAKER 10A 2POLE UL489
- 7) CB1 - CIRCUIT BREAKER 6A 2POLE UL489

## TB1 Terminal Block Assembly 230V



**WARNING** - Disconnect the product from the mains supply before replacing the fuse(s).

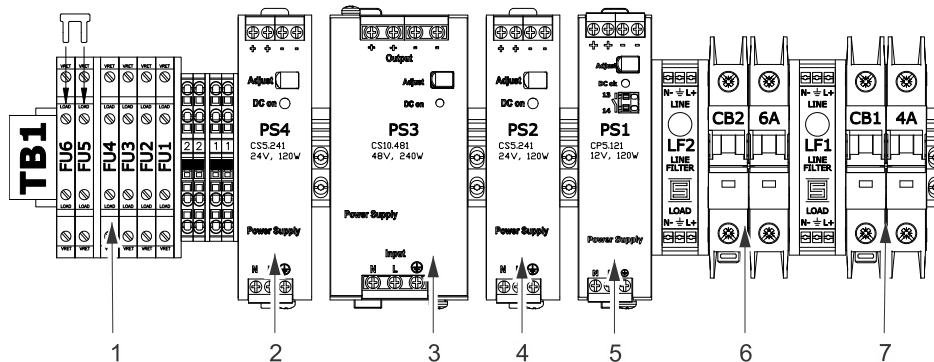

**FUSES:**

- FU1 - 5A, 250V
- FU2 - 5A, 250V
- FU3 - 5A, 250V
- FU4 - 5A, 250V
- FU5 - 5A, 250V
- FU6 - 5A, 250V

- 1) Fuse block. Note: a 2-pole jumper is installed in the load terminals of FU5 - FU6.
- 2) PS4 - POWER SUPPLY 24VDC 120WATT DIN MOUNT 100-240VAC
- 3) PS3 - POWER SUPPLY 48VDC 240WATT DIN MOUNT 100-240VAC
- 4) PS2 - POWER SUPPLY 24VDC 120WATT DIN MOUNT 100-240VAC
- 5) PS1 - POWER SUPPLY 12VDC 120WATT DIN MNT 100-240VAC
- 6) CB2 - CIRCUIT BREAKER 6A 2POLE UL489
- 7) CB1 - CIRCUIT BREAKER 4A 2POLE UL489

## Chapter 7 Part Changeover FHCP

---

When changing parts to inspect, you only need to change the part program (if you have a part program already set up for the newly inspected part type).

This will load the proper inspections, lighting, and guide rail settings, if applicable (as long as these were previously set).

### Part Changeover

When changing parts to inspect, you only need to change the part program (if you have a part program already set up for the newly inspected part type).

This will load the proper inspections, lighting, and guide rail settings, if applicable (as long as these were previously set).

*Some menu items are only available to advanced level users.*

#### **What you need:**

User permission to Switch Part Program

#### **To change parts:**

1. Log in.
2. Click the part drop-down menu.

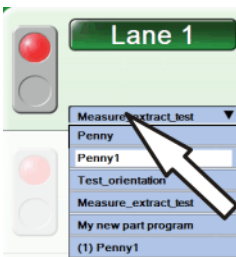

3. Click the name of the new part to inspect. The new part program is loaded on the Intellispec.
4. Put the lane online to begin inspecting new parts.

Lane-specific information is contained in each Part Program. Everything you set up have previously set up is stored: camera information, lighting information, calibration information, and inspections.

### Observe the Part Image

When adjusting the focus, aperture, or height for any inspection module, it is helpful to use Offline Imaging so that you can immediately see the effect of an adjustment on the image quality.



### To use Run in Immediate Mode:

1. Make sure the lane is offline.



2. Right-click a sensor button.
3. Select Offline Imaging from the menu.
4. Click the Run button under Immediate Mode, then run a part through the inspection module.

While the system is in this mode, you will be able to make adjustments to focus, aperture, or camera height.

## Camera Height Adjustment FHCP 3X

The camera height for the Main and Color cameras is adjusted by motors that you control through the user interface software. You only need to adjust the camera height when you set up a new part program. After you adjust the camera height, save and exit the screen, the adjustment data is saved with the current part program.

*Note: you only need to adjust camera height once for the color cameras. Both cameras are on a plate and they move together. Once you save the settings for one color camera, you do not need to repeat the procedure for the other color camera. You will need to adjust height for the main camera separately.*

### You will need:

- A stopped conveyor. You need to adjust the height using a part that is not moving.
- A part that represents the part you are going to inspect and set up a part program for.

### To adjust camera height:

## Chapter 7

1. Make sure the system is offline.
2. Make sure the desired part program is selected.
3. Place a part in the center of the inspection tunnel.
4.  From Lane Overview or Sensor Overview mode, select the Tools button | Part Setup | Adjust Servo Setpoints. If you selected the menu from Lane Overview mode, select the camera you want to adjust. This is already selected if you entered the screen from Sensor Overview mode.
5. Select "Adjust Lift" from the drop-down menu.

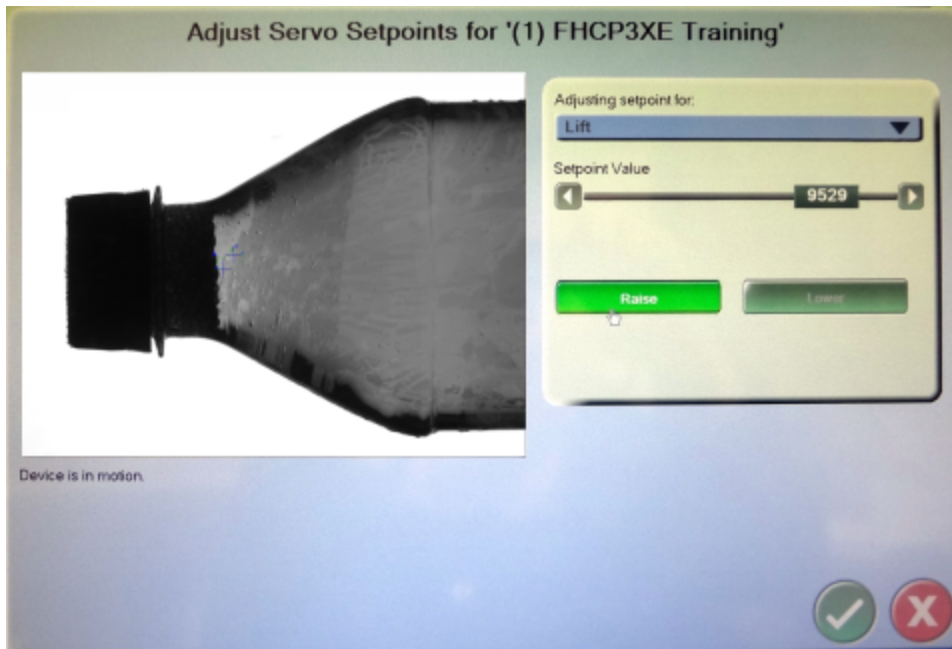

6. Press either the Raise or Lower button, depending which way you want to move the camera. The camera(s) will start moving inside the inspection module. You should see the lights flashing and an image on the screen.
7. Look at the image on the screen and wait until the part moves in the image. When the part is almost where you want it, press the Raise or Lower button again (the button you pressed in the previous step). The motor continues to run a couple seconds after you press the button.
8. Repeat steps 6 and 7 until the part image is at the desired height, as shown below.
9. If you are done adjusting the camera and guide rails, click the OK button and exit. The settings are saved with the current part program.
10. Repeat this procedure the other camera. NOTE: you only need to adjust the height once for both color cameras - they are on a plate and move together. You will adjust the main camera separately.

We recommend that the part image is approximately 100 pixels from the top of the image.

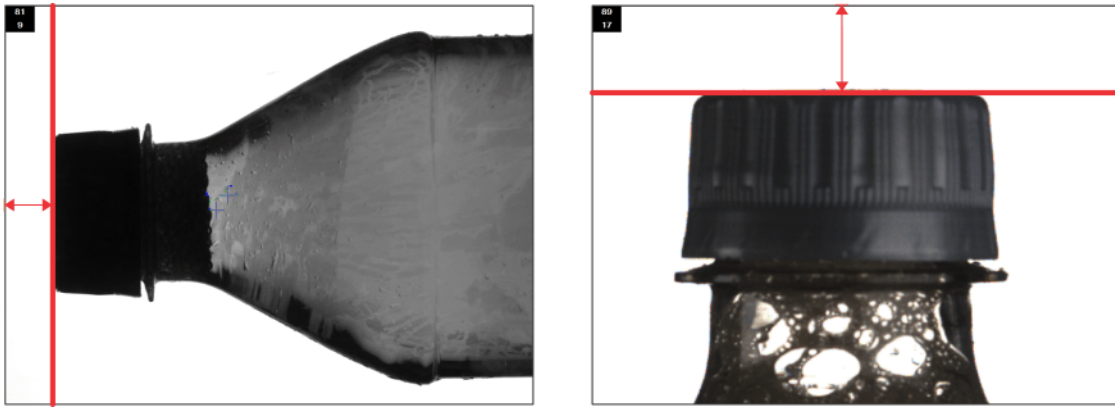

## Guide Rail Adjustment FHCP 3X S6 (Optional)

*Note: Guide Rails are only installed on some systems where additional part handling control is needed. This is an option to purchase separately.*

If this option is installed, the guide rails ensure that bottles are presented uniformly to the cameras. Rail width is controlled by a stepper motor system. The width adjusts automatically when changing part programs, and manually through the user interface.

The Guide Rails are adjusted by a motor that you control through the user interface software. You only need to adjust the guide rails when you set up a new part program. After you adjust the guide rails, save and exit the screen, the adjustment data is saved with the current part program.

- When the system shuts down, the guide rails move to home position.
- When the system powers up, the guide rails calibrate themselves and move into the correct position for the currently selected part program.

### You will need:

- A stopped conveyor. You need to adjust the rails using a part that is not moving.
- A part that represents the part you are going to inspect and set up a part program for.

### To adjust the guide rails:

1. Make sure the system is offline.
2. Make sure the desired part program is selected.
3. Place a part in the center of the inspection tunnel.
4.  From Lane Overview or Sensor Overview mode, select the Tools button | Part Setup | Adjust Servo Setpoints. If you selected the menu from Lane Overview mode, select a sensor. This is already selected if you entered the screen from Sensor Overview mode.
5. Select "Adjust Rails" from the drop-down menu.
6. Press either the Narrower or Wider button, depending which way you want to move the rails. The rails will start moving inside the inspection module.

## Chapter 7

7. Look at the bottle and rails and wait for the rails to move. When the rails are almost where you want them, press the Narrower or Wider button again (the button you pressed in the previous step). The motor continues to run a couple seconds after you press the button.
8. Repeat steps 6 and 7 until the rails are in the desired position for your part. Make sure that the bottles have enough room to pass through the rails without touching them.
9. If you are done adjusting the camera and guide rails, click the OK button and exit. The settings are saved with the current part program.



# Wiring Diagram FHCP3X S6 Sheet 2 of 12

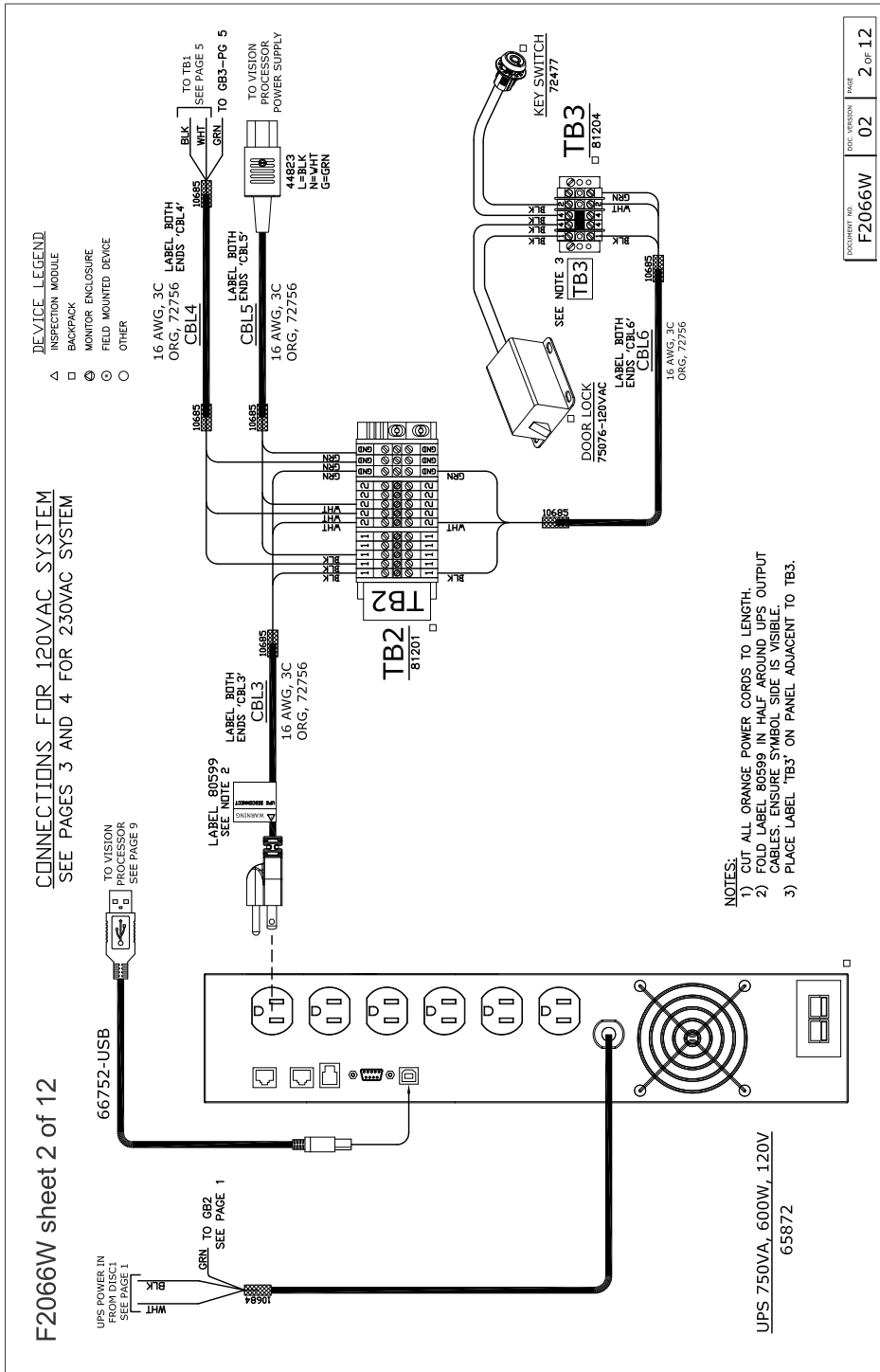



# Wiring Diagram FHCP3X S6 Sheet 4 of 12

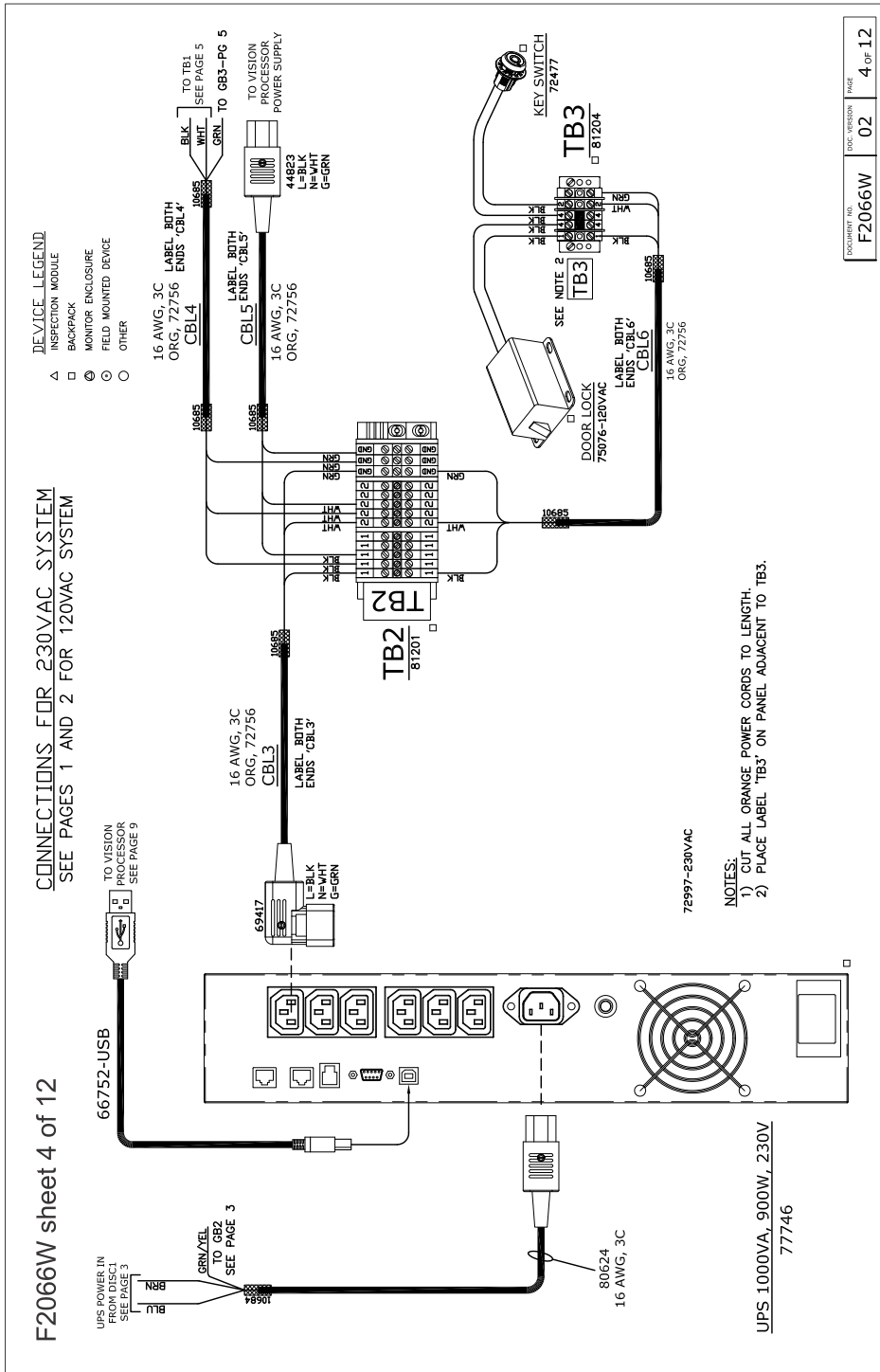





# Wiring Diagram FHCP3X S6 Sheet 7 of 12

F2066W sheet 7 of 12

- DEVICE LEGEND**
- △ INSPECTION MODULE
  - BACKPACK
  - ⊙ MONITOR ENCLOSURE
  - FIELD MOUNTED DEVICE
  - OTHER

PART TRACKER PCB ASSY  
78524

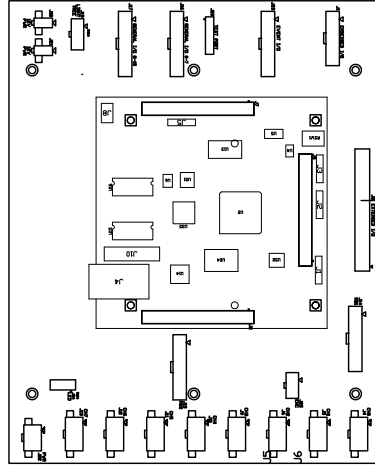

EXTENDED I/O PCB ASSY  
75626

SEE NOTE 1

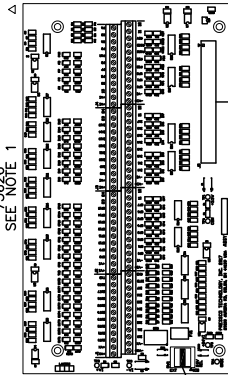

SW1-24V SELECTOR SWITCH:

- SET TO DESIRED POSITION:
- EXT-EXTERNAL 24VDC PS
- CTR-NO VOLTAGE
- XIO-EXTENDED I/O 24VDC

EXTERNAL 24V PS MUST BE CONNECTED TO +VX AND -VX.

NOTE: DO NOT CONNECT EXTERNAL PS TO +V1 OR -V1.

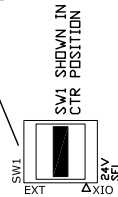

**NOTES:**

- 1) CUT INSULATION PAPER: 60182 TO FIT BACK OF PART TRACKER AND EXTENDED I/O ASSEMBLIES.
- 2) ROUTE (FOLDING AS NEEDED) THE RIBBON CABLES BEHIND THE PART TRACKER AND EXTENDED I/O BOARDS SUCH THAT THE CABLES ARE SANDWICHED BETWEEN INSULATION PAPER AND THE BACK OF ENCLOSURE.
- 3) USE CLIPS: 10698, TO SECURE RIBBON CABLES TOGETHER AT POINTS IN BETWEEN PCBs.

DOCUMENT NO. F2066W  
DOC. VERSION 02  
PAGE 7 OF 12











## Chapter 9 Troubleshooting FHCP Systems

See the following table for a list of symptoms with possible causes and solutions. For other problems or further help, contact Pressco.

Symptom	Probable Cause	Solution
No image (image is black or solid cream color)	Part program was not changed during part changeover	Change part program to match the part you are inspecting <a href="#">"Part Changeover" on page 39</a>
	Lighting not set up correctly	Set up lighting Basic Adjust Lighting or Advanced Adjust Lighting See the Intellispec Software Guide for instructions
	Part tracker board not communicating	Restart the system <a href="#">"Restarting the FHCP System" on the next page</a>
System log reads "missed acquisitions" or "Part Tracker Error" Error message on screen that reads "Part Tracker Error - Reset Part Tracker" Error message on screen: "Part Tracker Exception"	Part tracker board not communicating	Restart the system <a href="#">"Restarting the FHCP System" on the next page</a>

### Lockout Instructions



*WARNING- Potential hazardous voltage from the UPS. Use caution when servicing.*

#### **Before servicing any electrical or mechanical components inside the FHCP system:**

1. Power off the system using power switch DISC 1. Power On/ Off
2. Carefully open the FHCP computer and inspection module doors. Accessing the internal components
3. Locate the circuit breaker lockout clips. These are shipped with the system, and should be stored inside the unit.
4. Install the circuit breaker lockout clips, as shown below, and attach a lock. This will ensure that no incoming power (if applicable) will reach the unit.

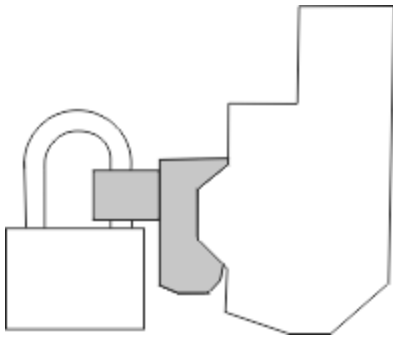

---

## Resetting the Part Tracker Board in FHCP

If you get an error message about the part tracker board, you may need to reset it. To reset the Part Tracker board in the FHCP system, restart the system. This will clear errors and reset the hardware. ["Restarting the FHCP System" below](#)

---

## Restarting the FHCP System

You may need to restart the system if power or communication has been lost. Symptoms may include that the inspection module light has stopped flashing, and the system is no longer taking pictures. Restarting the system will reconnect the Vision Processor with the Part Tracker.

*Note: if the power to the UPS is interrupted for more than 30 seconds, the software will automatically shut itself down and then shut down the Vision Processor PC. The software will restart. You will just need to log in and put the system back online.*

## Restarting the system

If your system has stopped communicating, or the software has stopped operating, we recommend that you restart the whole system. This will reset the software, the inspection module, and all the communication devices of the system.

### **To restart the system:**

1. Turn off the main power switch (DISC 1). The system will shut down, including a controlled shut down of the software.
2. Wait until the software and all the components have shut down, and then wait for about 40 more seconds to allow the electronic components to reset.
3. Turn on the main power switch (DISC 1). The system will start, and the Intellispec software will load. Log in to begin using the system.

*Note: The system restart takes several minutes to complete.*

If the system restart does not fix the problem, try one of the solutions below, or contact Pressco. (How to Contact Pressco)

## Restarting the Software Application

You may need to restart the software if you see a software error that, for some reason, may not have been cleared by restarting the entire system.

You must have proper user permissions to exit the software. This prevents unauthorized system shut-downs. Contact your system administrator if you need user permissions.

*Important - When restarting the software, it is important to choose the correct option from the Shut Down System menu. Only select Shut Down Intellispec and Restart Computer as described below.*

### To restart the Intellispec software:

1. Log in.
2. Take the system offline. (Repeat for all lanes if necessary)

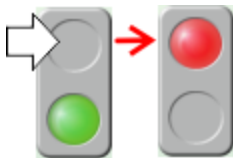

3.   Exit the software: Home | Tools | Shut Down Intellispec and Computer.

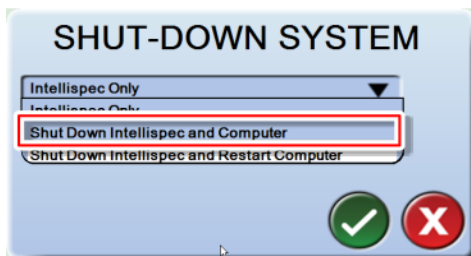

4.  Click the OK button. The Intellispec software and computer shuts down and restarts. Your system may be configured to go online at startup. Otherwise, the software will come up in System Overview mode where you can log in to continue operating the system.

## Rebooting the computer

If restarting the software application does not clear the errors, or the software does not restart, or you see the "System in Transition" message, try rebooting the computer.

### To reboot the computer:

1. Connect the Mechanical keyboard (MKB) to the USB port under the monitor, closest to the center of the monitor. The keyboard is stored inside the Control Cabinet.
2. Press Ctrl + Alt + Delete on the mechanical keyboard.
3. Use the Log Off option to log off of Intellispec.
4. At the Windows Login Prompt, enter "pvpass" as the password for the Intellispec user account. Once login is complete the application software will be launched.
5. Remove the Mechanical keyboard and properly store it.

*Note: The system reboot takes several minutes to complete.*

# Chapter 9 Extended I-O S6

This section contains information about the optional Extended I/O board in Intellispec Series 6 systems.

*Note: In some systems, such as FHCP inspection systems, the Extended I/O board is always included (not optional).*

## Extended I-O Board S6

This optional module provides additional input and output ports for communicating with the Intellispec Series 6 system. The board may be installed within a cluster box or within an inspection module. The board is connected to the lane's Part Tracker board via a ribbon cable.

*Note: Each Extended I/O board handles only one lane.*

*Note: Extended I/O is not available with an Embedded Cluster Box.*

Some signals must be enabled in the software through the "Extended I-O Configuration" on page 69.

Below is the layout for the Extended I/O board. "Extended I-O Signals S6" on the next page

Switch SW1 selects Intellispec 24V power supply or User 24V power supply. "Extended I-O Switch SW1 Selection" on page 67

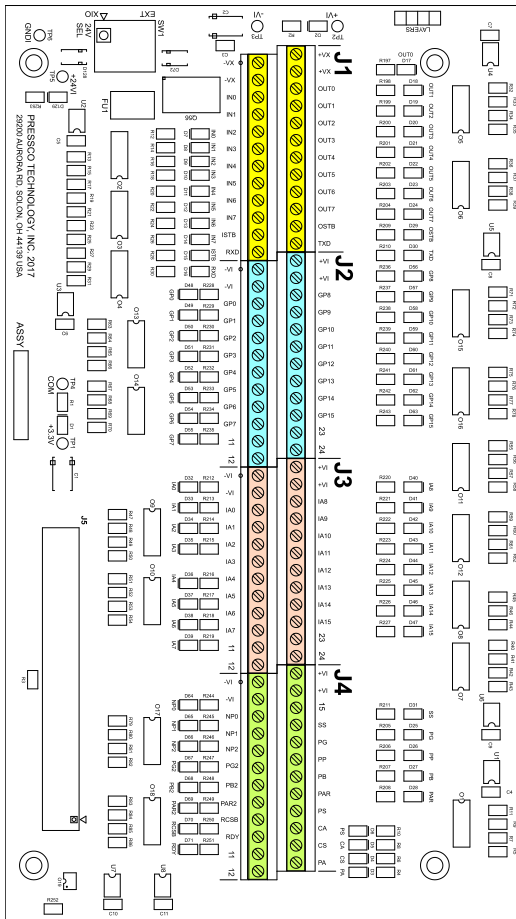

## Extended I-O Signals S6

Switch SW1 selects Intellispec 24V power supply or User 24V power supply.

### Labels used on the board: Series 6

Signal	Label	Signal	Label
User +24VDC	+VX	System State	SS
User 24VRET	-VX	Part Present	PP
+24VDC	+VI	Part Good	PG
24VRET	-VI	Part Bad	PB
Generic Input n	INn	Part at Reject	PAR
Generic Output n	Outn	Part Good 2	PG2
Input Strobe	ISTB	Part Bad 2	PB2
Output Strobe	OSTB	Part at Reject 2	PAR2
Group n	GPn	Print Statistics	PS
Inspection Alarm n	IAn	Clear Alarms	CA
Not Processed n	NPn	Clear Statistics	CS
Reject Confirm Sensor Blocked	RCSB	Preform Alarm	PA
RS232 Transmit	TXD	System Ready	RDY
RS232 Receive	RXD		

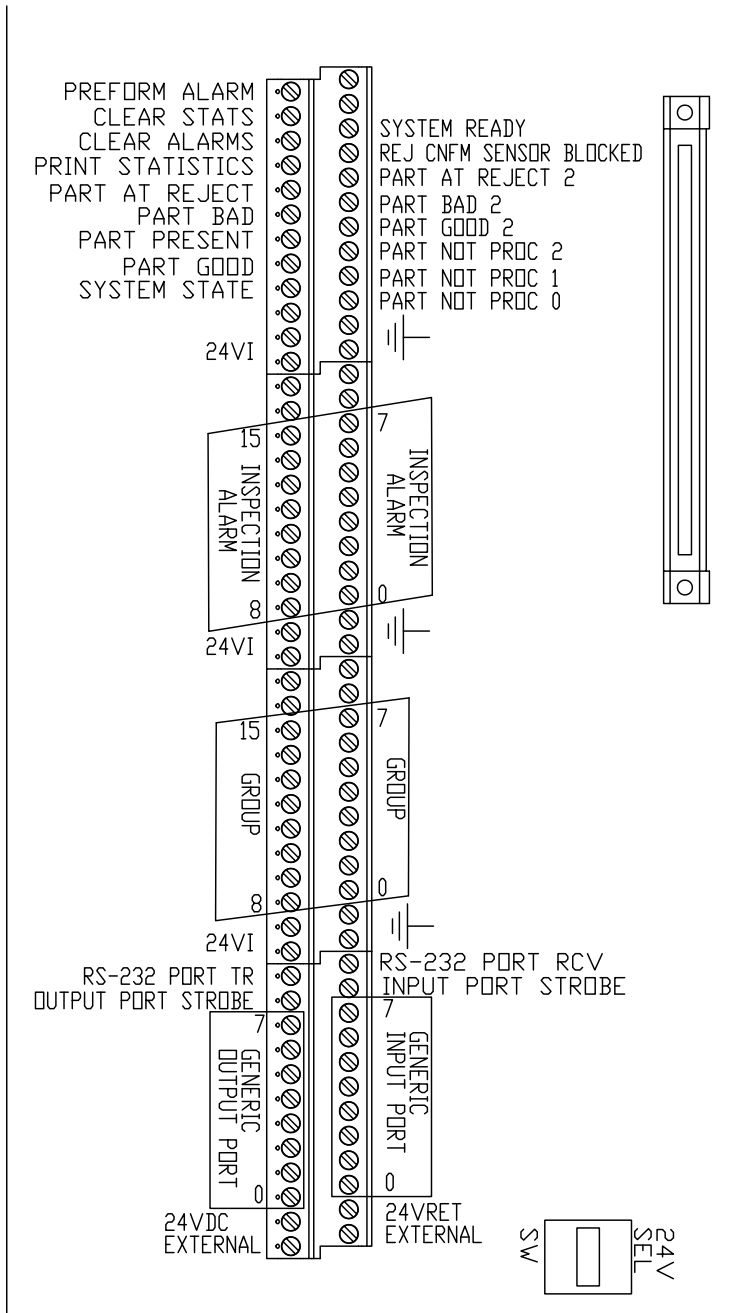

**Note:** some signals are not currently used

All Extended I/O inputs are PNP. Outputs are selectable to be either open collector or open emitter. However, that selection applies to ALL output signals.

The input and power LEDs are visual indicators. The maximum current output is 50mA. See also information about Extended I/O circuits.

Terminal	Signal and Indicator LED label	Input (I) or Output (O)	Comments
J1-1	User 24VRET (-VX)		
J1-2	User 24VRET (-VX)		

Chapter 9

Terminal	Signal and Indicator LED label	Input (I) or Output (O)	Comments
J1-3	Generic Input 0 (IN0)	I	Port 0 and Port 1 used in Remote Part Program Switching  Generic Input bits may be used for Auto-Learn or Alternate Part Processing
J1-4	Generic Input 1 (IN1)	I	
J1-5	Generic Input 2 (IN2)	I	
J1-6	Generic Input 3 (IN3)	I	
J1-7	Generic Input 4 (IN4)	I	
J1-8	Generic Input 5 (IN5)	I	
J1-9	Generic Input 6 (IN6)	I	
J1-10	Generic Input 7 (IN7)	I	
J1-11	Input Strobe (ISTB)	I	
J1-12	RS232 RX (RXD)	I	
J1-13	User +24VDC (+VX)		
J1-14	User +24VDC (+VX)		
J1-15	Generic Output 0 (OUT0)	O	
J1-16	Generic Output 1 (OUT1)	O	
J1-17	Generic Output 2 (OUT2)	O	
J1-18	Generic Output 3 (OUT3)	O	
J1-19	Generic Output 4 (OUT4)	O	
J1-20	Generic Output 5 (OUT5)	O	
J1-21	Generic Output 6 (OUT6)	O	
J1-22	Generic Output 7 (OUT7)	O	
J1-23	Output Strobe (OSTB)	O	Pulsed When data of Generic Output Port (0-7) is set
J1-24	RS232 TX (TXD)	O	

Terminal	Signal and Indicator LED label	Input (I) or Output (O)	Comments
J2-1	24VRET (-VI)		
J2-2	24VRET (-VI)		
J2-3	Group 0 (GP0)	O	Pulses for 12 ms when an inspection fails in the user-defined group (online mode only)  Walk By Setup
J2-4	Group 1 (GP1)	O	
J2-5	Group 2 (GP2)	O	
J2-6	Group 3 (GP3)	O	
J2-7	Group 4 (GP4)	O	
J2-8	Group 5 (GP5)	O	
J2-9	Group 6 (GP6)	O	
J2-10	Group 7 (GP7)	O	

Chapter 9

Terminal	Signal and Indicator LED label	Input (I) or Output (O)	Comments
J2-11	no connection		
J2-12	no connection		
J2-13	+24VDC (+VI)		
J2-14	+24VDC (+VI)		
J2-15	Group 8 (GP8)	O	See comments for Group 0 - 7 above
J2-16	Group 9 (GP9)	O	
J2-17	Group 10 (GP10)	O	
J2-18	Group 11 (GP11)	O	
J2-19	Group 12 (GP12)	O	
J2-20	Group 13 (GP13)	O	
J2-21	Group 14 (GP14)	O	
J2-22	Group 15 (GP15)	O	
J2-23	no connection		
J2-24	no connection		

Terminal	Signal and Indicator LED label	Input (I) or Output (O)	Comments
J3-1	24VRET (-VI)		
J3-2	24VRET (-VI)		
J3-3	Inspection Alarm 0 (IA0)	O	Set when the associated alarm condition occurs and stays active until the alarm is cleared Lane Alarm Configuration and Sensor Alarm Configuration
J3-4	Inspection Alarm 1 (IA1)	O	
J3-5	Inspection Alarm 2 (IA2)	O	
J3-6	Inspection Alarm 3 (IA3)	O	
J3-7	Inspection Alarm 4 (IA4)	O	
J3-8	Inspection Alarm 5 (IA5)	O	
J3-9	Inspection Alarm 6 (IA6)	O	
J3-10	Inspection Alarm 7 (IA7)	O	
J3-11	no connection		
J3-12	no connection		

Chapter 9

Terminal	Signal and Indicator LED label	Input (I) or Output (O)	Comments	
J3-13	+24VDC (+VI)			
J3-14	+24VDC (+VI)			
J3-15	Inspection Alarm 8 (IA8)	O	See comments for Inspection Alarm 0-7 above	
J3-16	Inspection Alarm 9 (IA9)	O		
J3-17	Inspection Alarm 10 (IA10)	O		
J3-18	Inspection Alarm 11 (IA11)	O		
J3-19	Inspection Alarm 12 (IA12)	O		
J3-20	Inspection Alarm 13 (IA13)	O		
J3-21	Inspection Alarm 14 (IA14)	O		
J3-22	Inspection Alarm 15 (IA15)	O		
J3-23	no connection			
J3-24	no connection			

Terminal	Signal and Indicator LED label	Input (I) or Output (O)	Comments
J4-1	24VRET (-VI)		
J4-2	24VRET (-VI)		
J4-3	Not Processed 0 (NP0)	O	Pulses for 12 ms when a part is not processed due to a system malfunction (online mode only)
J4-4	Not Processed 1 (NP1)	O	
J4-5	Not Processed 2 (NP2)	O	
J4-6	Part Good 2 (PG2)	O	Group B outputs. See Extended I/O Configuration
J4-7	Part Bad 2 (PB2)	O	
J4-8	Part at Reject 2 (PAR2)	O	
J4-9	Reject Confirm Sensor Blocked (RCSB)	O	Reject confirm sensor signal pulse width exceeding programmed limit
J4-10	System Ready (RDY)	O	Steady state ON or OFF 24V.

Terminal	Signal and Indicator LED label	Input (I) or Output (O)	Comments
			ON = lane is online, no critical alarms are triggered, and no lost communication.  OFF = lane is offline, a critical alarm has been triggered, or communication is lost (example: part tracker communication lost).
J4-11	no connection		
J4-12	no connection		
J4-13	+24VDC (+VI)		
J4-14	+24VDC(+VI)		
J4-15	no connection		
J4-16	System State (SS)	O	Indicates whether the lane is online or offline. Online = active. Offline = inactive.
J4-17	Part Good (PG)	O	Pulses for 12 ms for each part declared good by the inspection
J4-18	Part Present (PP)	O	Pulses for 12 ms when the part present sensor detects a part
J4-19	Part Bad (PB)	O	Pulses for 12 ms for each part declared bad by the inspection
J4-20	Part at Reject (PAR)	O	Pulses for 12 ms for each part that crosses the reject point (online mode only)
J4-21	Print Statistics (PS)	I	Prints the lane statistics to currently configured printer or file  Schedule Reports
J4-22	Clear Alarms (CA)	I	Clears the lane alarms
J4-23	Clear Statistics (CS)	I	Clears the lane statistics
J4-24	Preform Alarm (PA)	I	Used only in special applications. Activated by the Preform Material Handling system.

**Test Points**

Function	Test Point
+3.3V	TP1
+3.3V Gnd	TP4
+24VDC (+VI)	TP2
24VRET (-VI)	TP3
+24VI	TP5
GNDI	TP6

## Extended I-O Switch SW1 Selection

Switch SW1 – 24VDC Selection:

### **SW1 has three positions:**

- XIO – In the XIO position 24VDC is supplied by the Intellispec power supply. 24VDC will be on terminals labeled +VI and 24VRET will be on terminals labeled –VI at J2, J3 and J4. Devices requiring 24VDC power should be connected to the +VI and –VI terminals. The terminals labeled +VX and –VX at J1 are not used. The 24VDC indicator LED D2 will be on if SW1 is in this position. There is no isolation from the Intellispec power supply. See Figure 1.
- CTR – In the center position there is no connection to a 24VDC source. There will be no voltage present at the terminals labeled +VI and –VI at J2, J3 and J4. The CTR position is not labeled on the PCB. The 24VDC indicator LED D2 will be off if SW1 is in this position. See Figure 2.
- EXT – In the EXT position 24VDC is supplied by an external 24VDC power supply. The external 24VDC must be connected to the +VX terminals and the external 24VRET must be connected to the –VX terminals. Devices requiring 24VDC power should be connected to the +VI and –VI terminals. The 24VDC indicator LED D2 will be on if SW1 is in this position. The external power supply and signals are isolated from the Intellispec power supply. See Figure 3.

*Note: 24VDC LED D129 is on to indicate 24VDC is supplied through the ribbon cable from the part tracker board.*



**WARNING:** Do not connect an external power supply to terminals labeled +VI or –VI.

**Figure 1 - SW1 in the XIO Position**

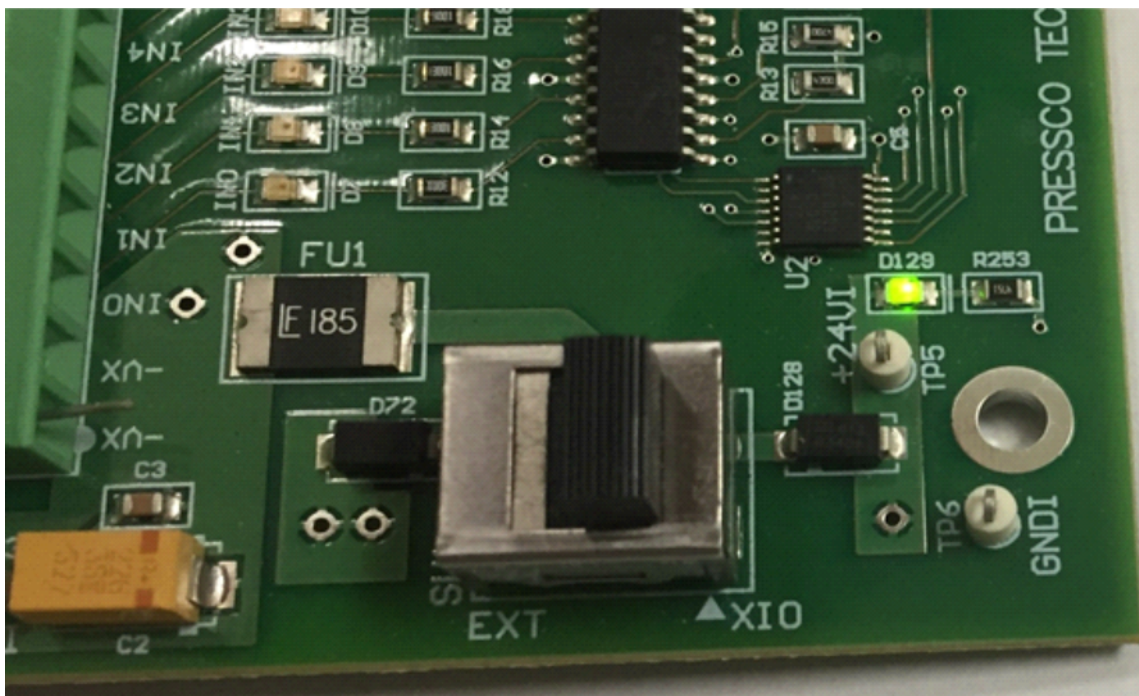

**Figure 2 - Switch SW1 in the CTR position**

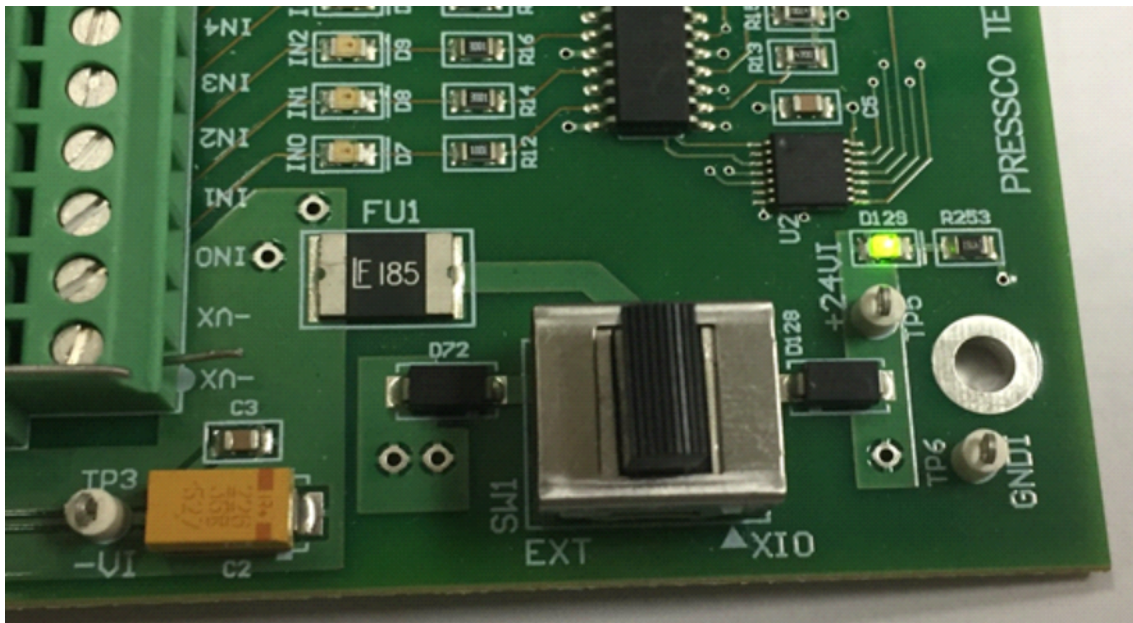

**Figure 3 - Switch SW1 in the EXT position**

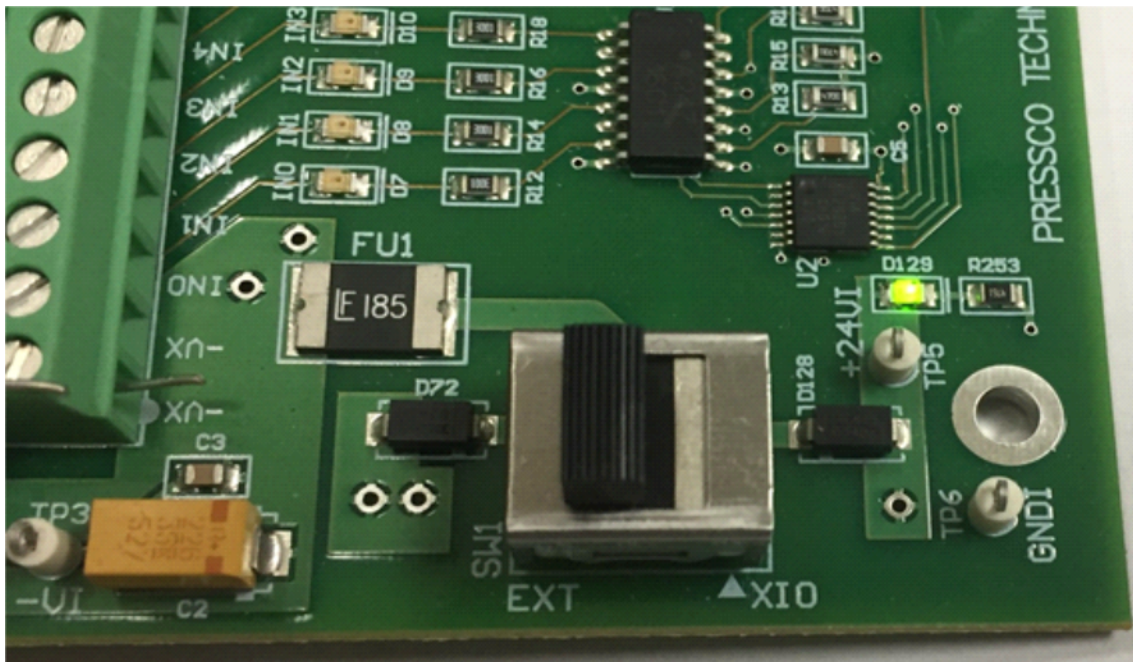

### Extended I-O Circuits S6

The following illustrations show typical input and output circuits you can use to communicate with your plant's PLC, or to connect external LEDs or light trees.

Specifications:

## Chapter 9

- Minimum dwell time of the input device is 1.1 ms
- Maximum output load is 50 mA
- Default value of output pulse is 12ms. Some output signals, such as alarms, must be cleared on the Intellispec before they turn off.

### Default timing of pulsed output

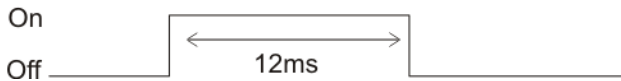

The following illustration shows a typical circuit that can be used to clear alarms.

### CLEAR ALARMS - INPUT

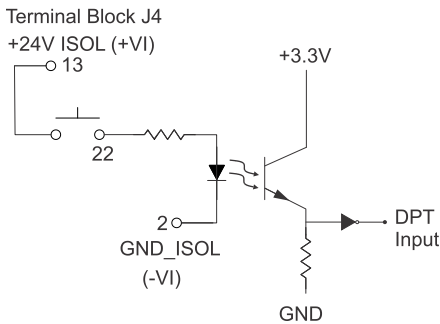

The following illustration shows a typical circuit that can be used for a group output.

### GROUP 1 - OUTPUT

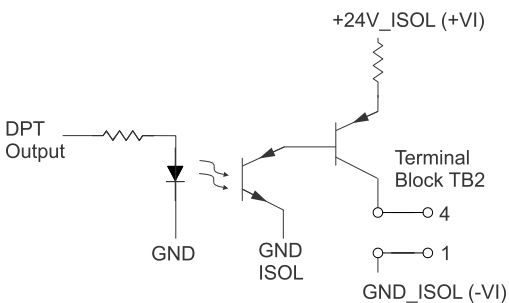

## Extended I-O Configuration

Enable input or output signals to perform a function on the Intellispec system or monitor the production lane in your plant. These settings must be done for each Extended I/O board for each lane.

See also the sections about Extended I/O and Extended I/O Signals in the Intellispec Hardware Guide.



To get to this screen: From Lane or Sensor Overview mode, select Tools | Hardware Setup | Extended I/O Configuration.

This screen displays some of the inputs and outputs on the optional extended I/O board.

If one of the extended I/O ports is used it must be enabled here in the software, and the hardware must be connected appropriately.

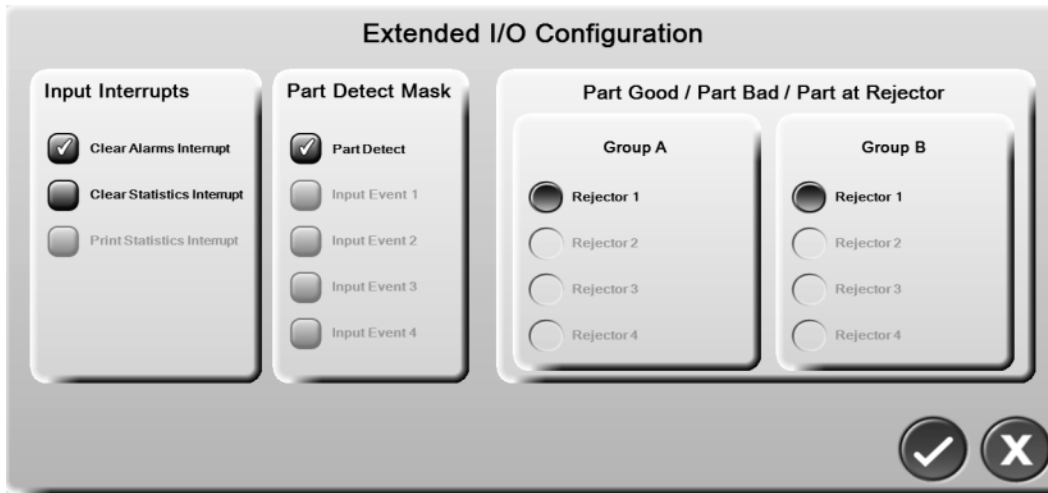

### ***Input Interrupts***

These signals produce an input pulse to the Intellispec to perform the following functions.

**Clear Alarms Interrupt** Clear the lane alarms.

**Clear Statistics Interrupt** Clear the lane statistics.

**Print Statistics Interrupt** Print the lane statistics to the currently configured printer or file. See also Schedule Reports.

### ***Part Detect Mask***

Choose which Part Detect or other input events to trigger the Part Present output on the Extended I/O board. This is an OR function. Any enabled Part Detect signal or Input Event that goes active will activate the Extended I/O Part Present output.

**Part Detect** The signal goes active when the sensor detects a part.

**Input Event N** The Part Tracker board accepts up to five\* input events (Part detectors or other sensors). Part tracking is always controlled by the Part Detect signal (Input Event 0). You might use other input events (1 - 4) in your system to trigger the Part Present output signal. \*Only if your system has an 8-channel Part Tracker board. If your system has a 2-channel Part Tracker board, then only one Part Detect signal is used. The other input events are not available.

### ***Part Good/ Part Bad/ Part at Rejector***

Choose which rejector signal to activate the Part Good, Part Bad, and Part at Rejector signals on the Extended I/O board. After a part is inspected, the system determines whether the part is good or bad. As the part passes by Rejector 1, 2, 3, or 4, the Part Good/ Part Bad/ and Part at Rejector signals are activated on the Extended I/O board. There are two groups of Part Good/ Part Bad/ and Part at Rejector signals - Group A and Group B. You choose which rejector is associated with Group A and/or Group B. You can have both groups associated with the same rejector, if desired. See Extended I/O signals in the Intellispec hardware guide

Note: If your system has a 2-channel Part Tracker board, then the lane has up to two rejectors. If your system has an 8-channel Part Tracker board, then the lane has up to four rejectors.

**Example 1 below**

Group A is triggered when the part passes Rejector 2, and Group B is triggered when the part passes Rejector 4. The illustration below shows a basic block diagram with a conveyor with four rejectors. Those rejectors output a signal to the Extended I/O board, based on the Extended I/O configuration.

R = Rejector

PG = Part Good signal, Group A and Group B

PB = Part Bad signal, Group A and Group B

PaR = Part at Reject signal, Group A and Group B

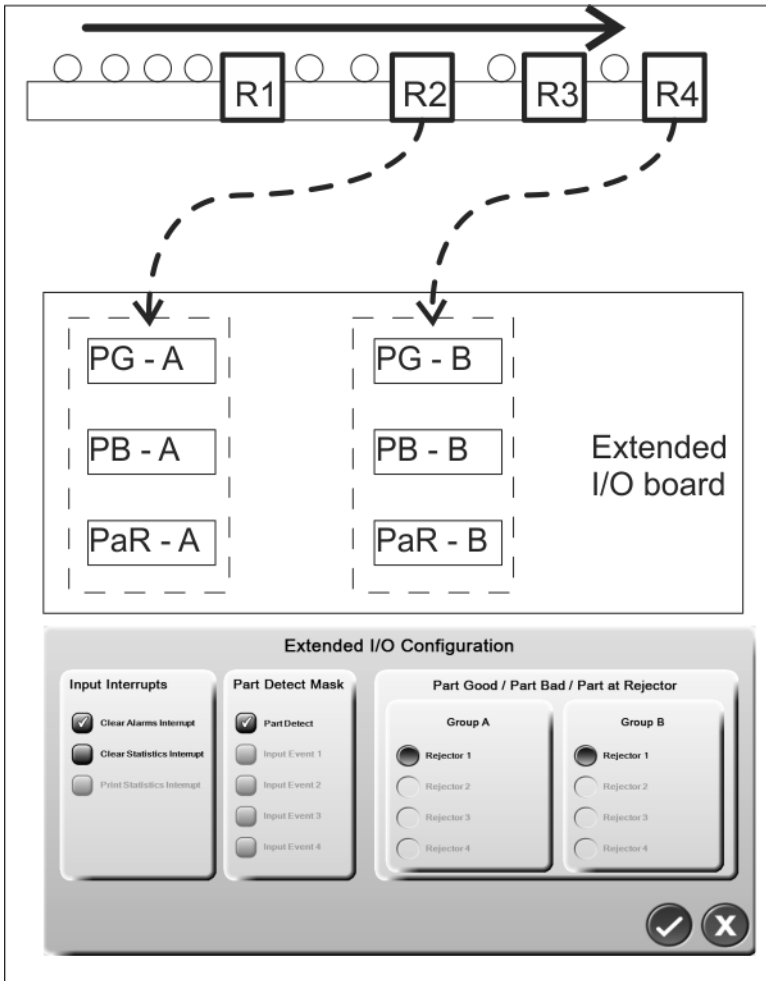

**Example 2 below:**

Group A is triggered when the part passes Rejector 2, and Group B is also triggered when the part passes Rejector 2.

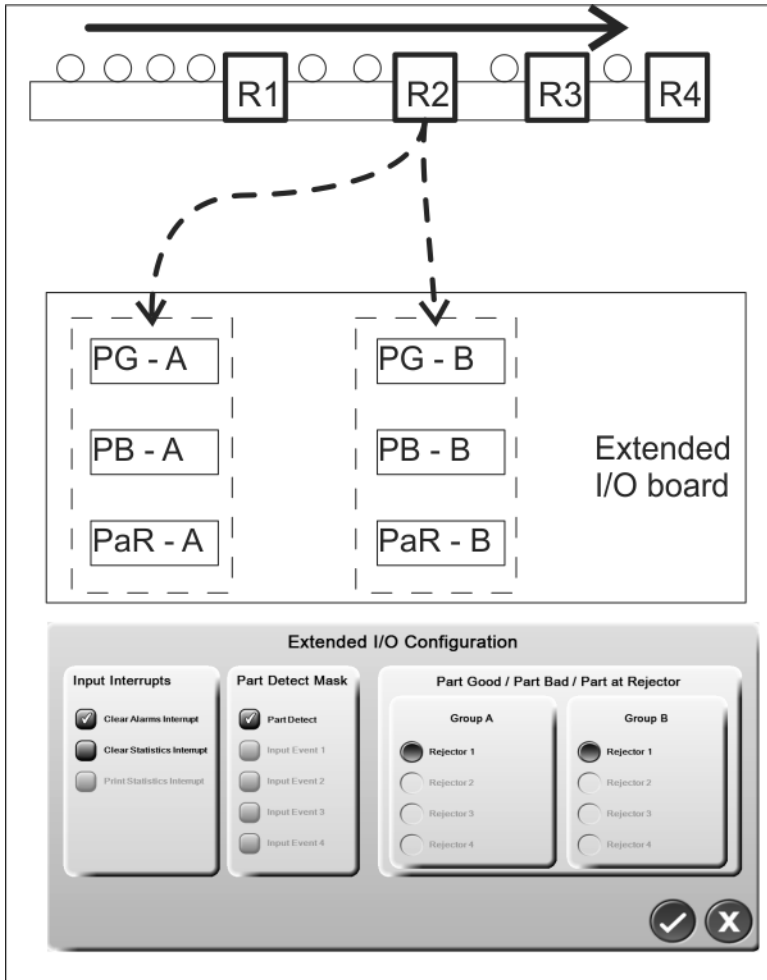

## Chapter 10 Maintenance

---

### *When carrying out maintenance or repair work:*



Disconnect master switch. For switch locations, refer to the Power Up and Power Down section.



Before starting the machine, ensure that no person is close to the machine.



If maintenance or repair requires the disconnection or removal of safety or protection systems, this operation must be supervised by authorized personnel who must ensure the prevention of personal injury or damage to the machine. All machine movements must be performed with limited speed and limited movements.



Maintenance or repair work on electrical components must be carried out exclusively by authorized, trained personnel. When running tests with power connected, you must strictly comply with the rules provided.



Personnel working on higher parts of a machine must wear a harness and hook it on to the structure and must always move with extreme caution.



Never perform lubrication or maintenance procedures on mechanical parts with the machine running.

### *LED Caution:*



**CAUTION** - Possible hazardous optical radiation from LEDs. Do not stare at lamps.

---

## Cleaning the FHCP System Cabinet

This unit is built for a wash-down environment, and does not need any parts covered during plant wash-down or unit cleaning.

After a plant wash-down, or at least once per week, clean the exterior of the cabinet.

### *To clean:*

- Use stainless steel cleaner and clean, dry cotton rags, lint-free cloths, or soft non-abrasive paper towels
- Wipe the exterior surface of the cabinet after a wash-down, or once per week

---

## Cleaning the Vision Processor Filter

The filter should be cleaned once a month for best results. The filter is located on the side of the cabinet. Replace with a new filter when necessary. Note: You may need to clean the filters weekly depending on plant conditions

### *To clean the filter:*

1. Remove the four screws that hold the filter cover.
2. Remove the filter and clean it.

If the filter contains dry dust and dirt, rinse it in plain water

If the filter contains oily dust and dirt, clean it in soapy water, then rinse in clear water

1. Dry the filter completely, then place it back inside the cabinet.
2. Replace the filter cover and replace the four holding screws.

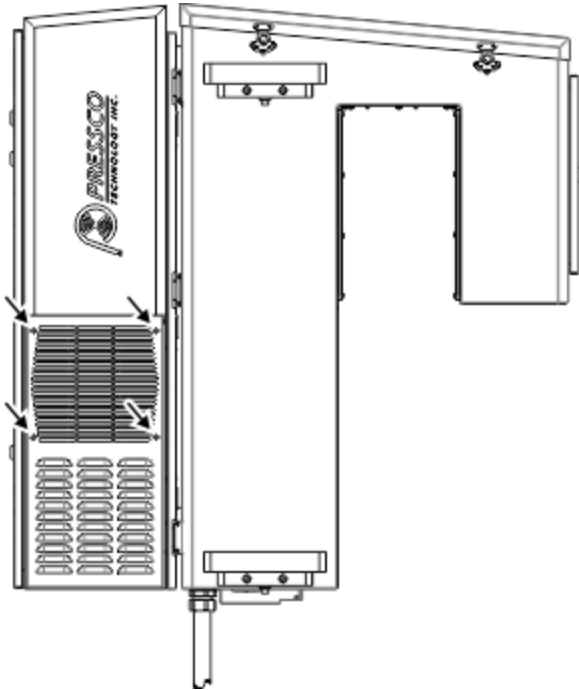

---

## Cleaning Optical Surfaces

**!** *Important - Debris and contamination could build up on both the glass and plastic surfaces. This dirt could appear in the inspection windows, causing false rejects of parts, or it could degrade lighting. Clean glass and plastic surfaces often to avoid false rejects.*

To maintain proper image quality and system performance, the clear glass and plastic surfaces on the Inspection Modules must be cleaned on a regular basis. Dirt and debris that appear in the image can cause false rejects. An oily film on optical surfaces can cause false rejects or missed defects.

---

## Cleaning Glass Surfaces

Glass surfaces that may require cleaning are:

- Camera Lens
- Beam Splitter (if present)
- Secondary lens (if present)
- Secondary mirror (if present)

**To clean glass surfaces:**

- Blow off dust with canned, compressed air
- Use a clean non-abrasive cloth dampened with lens cleaning solution
- Use lens tissue and lens cleaning solution on camera lenses
- If surface has compound on it, first clean with alcohol, then with lens cleaning solution

*Note: Cleaning frequency will depend on plant and process conditions.*

## Cleaning the Camera Lens

Under normal conditions, you do not need to clean these components, because they are inside the inspection module enclosure. Be sure to keep the inspection windows clean so that the optical components inside can properly detect parts and defects.

If these items need cleaning, follow the instructions below.



*Caution - Do not touch the lens with fingers or oily cloths.*

### **To clean the camera lenses:**

- Clean all camera lenses with lens tissue and lens cleaning fluid. Be careful not to alter the focus or aperture of the cameras.
- Re-adjust aperture and focus if needed.

---

## Cleaning Plastic Surfaces - FHCP

The inspection tunnel windows on both sides are plastic. They require periodic cleaning.

*Note: Cleaning frequency will depend on plant and process conditions.*

### **To clean plastic surfaces:**

- Use canned compressed air to blow away dust
- Use a clean, non-abrasive cloth dampened with mild soap and water solution. Saturate surface completely to let particles wash away.
- Dry the surface with clean, compressed air



*DO NOT: Use paper towels, paper napkins, or dry cloths – these may scratch surfaces*

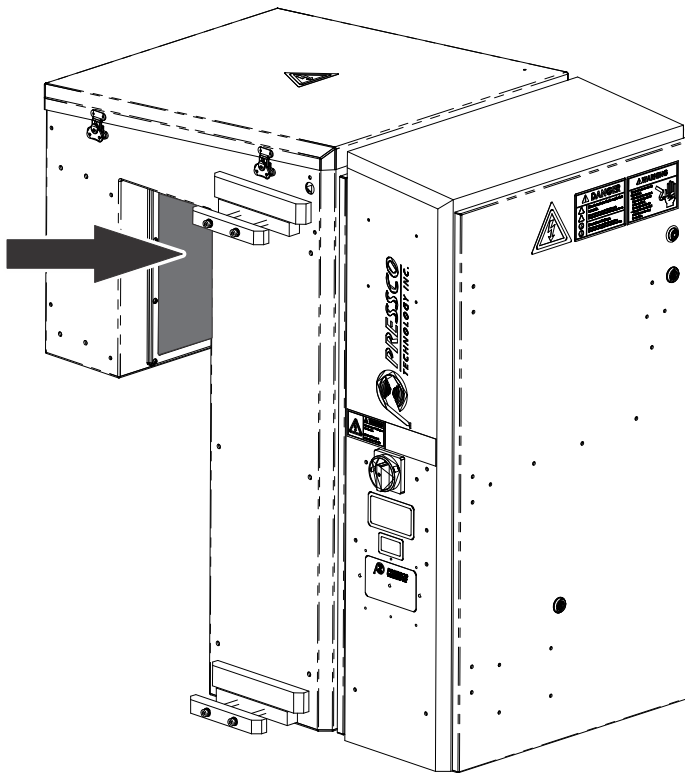

---

## Cleaning the Part Detector FHCP S6

Under normal conditions, you do not need to clean these components, because they are inside the inspection module enclosure. Be sure to keep the inspection windows clean so that the optical components inside can properly detect parts and defects.

If these items need cleaning, follow the instructions below.

### **To clean the part detector:**

Clean the part detector and reflector surfaces with a soft, clean, lint-free cloth dampened with a mild soap and water solution.

Do not use a glass cleaning solution or strong solvent on the plastic surfaces as they might be damaged.

*Note: The frequency of cleaning will depend on plant and process conditions.*

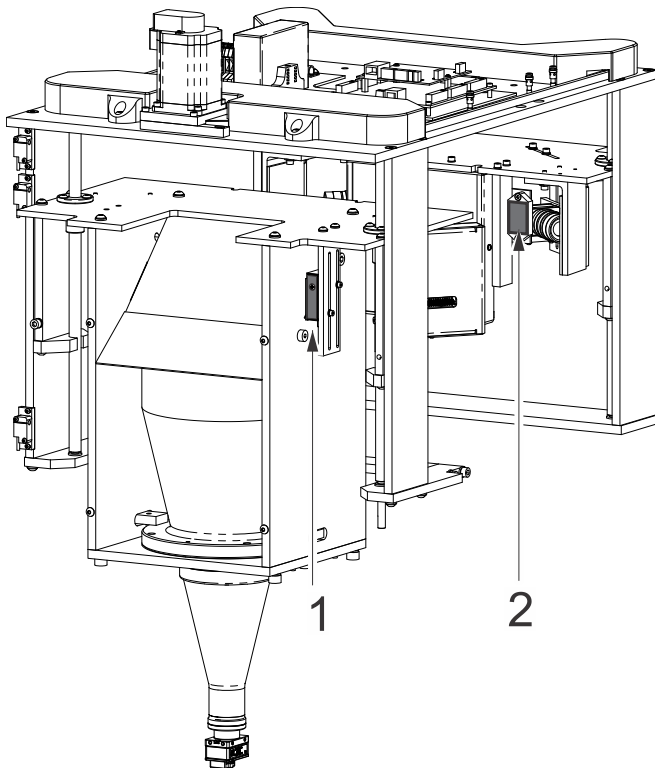

- 1 - Part detect sensor (lens is towards the center of the tunnel)
- 2 - Part detect reflector